

Technical Manual

Register 22 CONTENTS - ARK2

Contents	Page
<i>Technical Data ARK2 (DIN)</i>	2
<i>Technical Data ARK2 (ANSI)</i>	3
<i>Material Specification ARK2</i>	4
<i>Assembly Instructions ARK2</i>	5
<i>Disassembly Instructions ARK2</i>	6
<i>ARK2 - recommended tightening torques (Flange Connection)</i>	7
<i>ARK2 - K_v and C_v - Data</i>	8

Technical Data ARK2 (DIN)

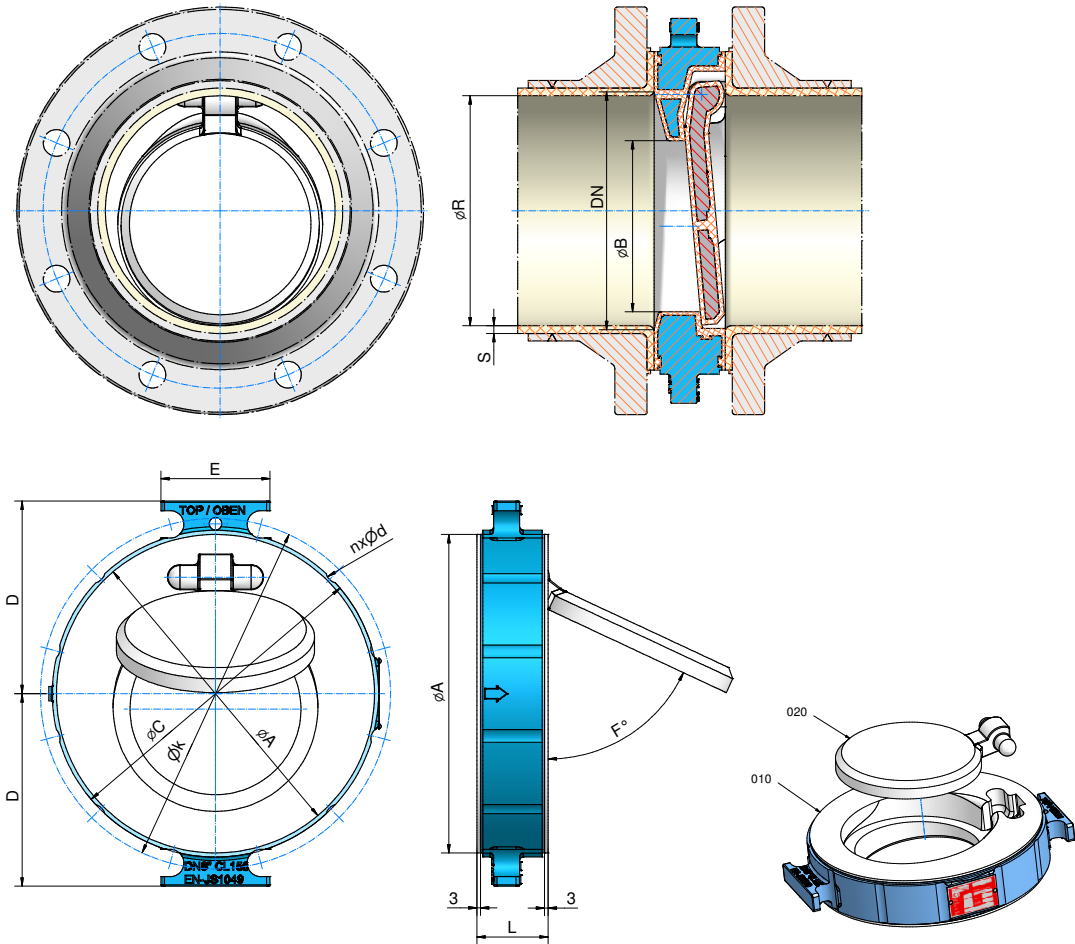

Face to Face dimensions	DIN EN 558 (col. 20)
Flange Connection	DIN EN 1092-2 PN16
DN200 and above	DIN EN 1092-2 PN10

DN / DIN		ØA	ØB	ØC	D	E	L	F	ØR	S	ØK	nxØd	weight
050	mm	98	25	101	70	66	43	62	48,5	3	125	4x19	kg 2,2
	inch	3,86	0,98	3,98	2,76	2,6	1,69	2,44	1,91	0,12	4,92	4x0,7	lbs 4,9
080	mm	130	45	133	85	89	46	65	75,5	3,5	160	8x19	kg 3,8
	inch	5,12	1,77	5,24	3,35	3,5	1,81	2,56	2,97	0,14	6,3	8x0,7	lbs 8,3
100	mm	164	66	170	105	54	52	65	98,1	4,5	180	8x19	kg 6,6
	inch	6,46	2,6	6,69	4,13	2,13	2,05	2,56	3,86	0,18	7,09	8x0,7	lbs 14,6
150	mm	215	105	219	135	70	56	65	149,3	5	240	8x23	kg 11,1
	inch	8,46	4,13	8,62	5,32	2,76	2,2	2,56	5,88	0,2	9,45	8x0,9	lbs 24,5
200	mm	268	144	275	162	92	60	63	193,5	6,5	295	12x23	kg 18,2
	inch	10,55	5,67	10,83	6,38	3,62	2,36	2,48	7,62	0,26	11,61	12x0,9	lbs 40,0
250	mm	324	184	336	198	69	68	65	246,4	7	355	12x28	kg 29,8
	inch	12,76	7,24	13,23	7,8	2,72	2,68	2,56	9,7	0,28	13,98	12x1,1	lbs 65,7
300	mm	386	230	406	234	87	78	62	293,7	8	410	12x28	kg 49,8
	inch	15,20	9,06	15,98	9,21	3,43	3,07	2,44	11,56	0,32	16,14	12x1,1	lbs 109,7
350	mm	429	250	445	255	95	78	62	321,6	9	470	16x28	kg 62,1
	inch	16,89	9,84	17,52	10,04	3,74	3,07	2,44	12,66	0,35	18,50	16x1,1	lbs 136,8
400	mm	480	300	510	290	77	102	58	368,8	10	525	16x31	kg 104,4
	inch	18,90	11,81	20,08	11,42	3,03	4,02	2,28	14,52	0,39	20,67	16x1,2	lbs 230,0

Technical Data ARK2 (ANSI)

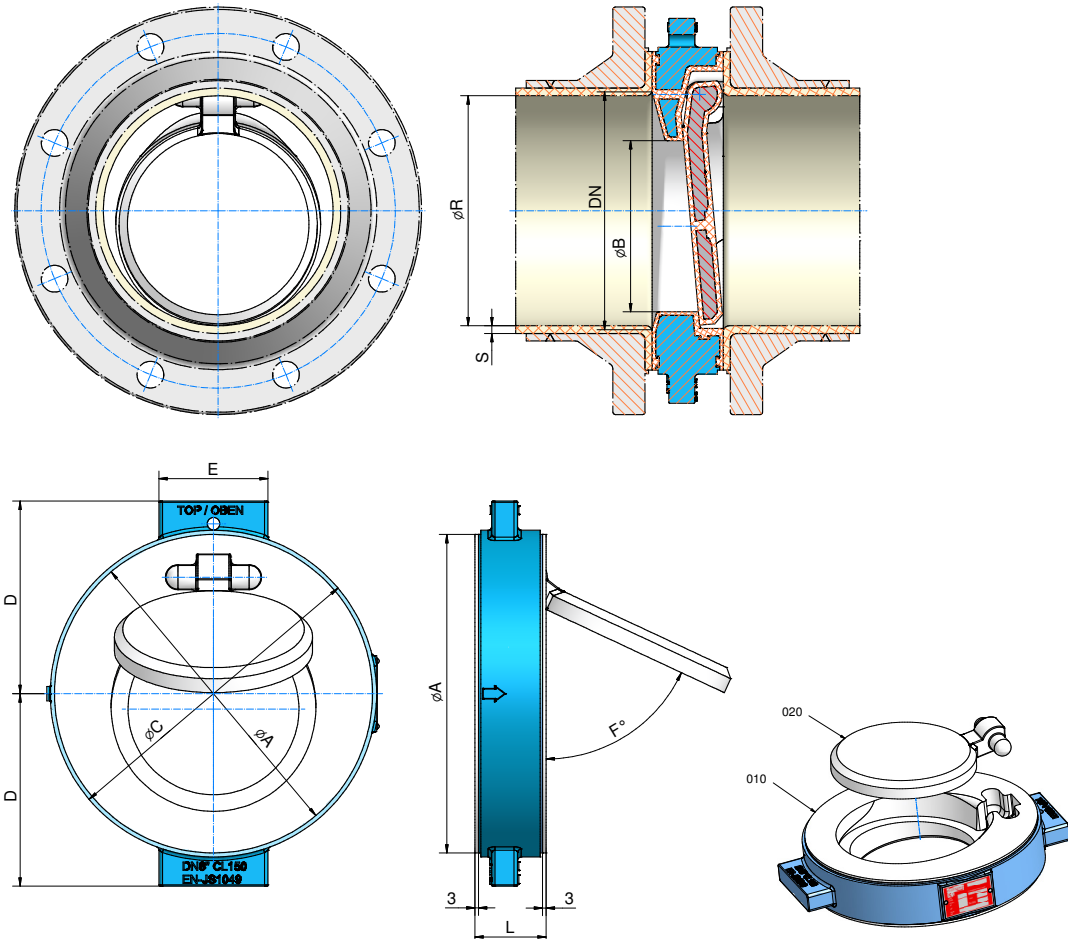

Face to Face dimensions ANSI B 16.10 Tab. 8
 (DN2" - 14" col. 3, DN16" col. 4)
 Flange Connection ANSI B 16.5

DN / ANSI	øA	øB	øC	D	E	L	F	øR	S	weight		
2"	mm	98	25	101	70	66	43	62	48,5	3	kg	2,2
	inch	3,86	0,98	3,98	2,76	2,6	1,69	2,44	1,91	0,12	lbs	4,9
3"	mm	130	45	133	85	89	46	65	75,5	3,5	kg	3,8
	inch	5,12	1,77	5,24	3,35	3,5	1,81	2,56	2,97	0,14	lbs	8,3
4"	mm	164	66	170	105	54	52	65	98,1	4,5	kg	6,6
	inch	6,46	2,6	6,69	4,13	2,13	2,05	2,56	3,86	0,18	lbs	14,6
6"	mm	215	105	219	135	70	56	65	149,3	5	kg	11,1
	inch	8,46	4,13	8,62	5,31	2,76	2,2	2,56	5,88	0,2	lbs	24,5
8"	mm	268	144	275	162	92	60	63	193,5	6,5	kg	18,2
	inch	10,55	5,67	10,83	6,38	3,62	2,36	2,48	7,62	0,26	lbs	40,0
10"	mm	324	184	336	198	69	68	65	246,4	7	kg	29,8
	inch	12,76	7,24	13,23	7,8	2,72	2,68	2,56	9,7	0,28	lbs	65,7
12"	mm	386	230	406	234	87	78	62	293,7	8	kg	49,8
	inch	15,2	9,06	15,98	9,21	3,43	3,07	2,44	11,56	0,31	lbs	109,7
14"	mm	429	250	445	255	95	78	62	321,6	9	kg	62,1
	inch	16,89	9,84	17,52	10,04	3,74	3,07	2,44	12,66	0,35	lbs	136,8
16"	mm	482	300	510	290	77	102	58	368,8	10	kg	104,4
	inch	18,98	11,81	20,08	11,42	3,03	4,02	2,28	14,52	0,39	lbs	230,0

Material specification ARK2

No.	Designation	Pieces	Material	Material-No. / DIN	ASTM / AISI
010	body	1	ductile iron / PFA	EN-JS1049 (GGG-40.3) / DIN EN 1563	A 395
020	disc				
	DN 50 - 80, DN 2" - 3"	1	PFA		
	DN 100 - 400, DN 4" - 16"	1	ductile iron / PFA	EN-JS1049 (GGG-40.3) / DIN EN 1563	A 395

Assembly Instruction ARK2

The general installation and maintenance instructions must be observed.

1. Insert disc **(020)** into the body **(010)**. Please observe that the flat surface of the disc is placed on the sealing surface of the body.
2. Place two studs **(A)** of the piping connection at the lowest position including the hexagon nuts.
3. Place the body **(010)** on the bolts **(A)** between the flanges of the pipe. While transportation make sure that the disc **(020)** is protected.
4. Assemble all bolts and screw the hexagon nuts lightly.
5. Position the raised face of the body **(010)** to the raised face of the piping.
6. Tighten the hexagon nuts according to the recommended tightening torques by using the criss-cross method.

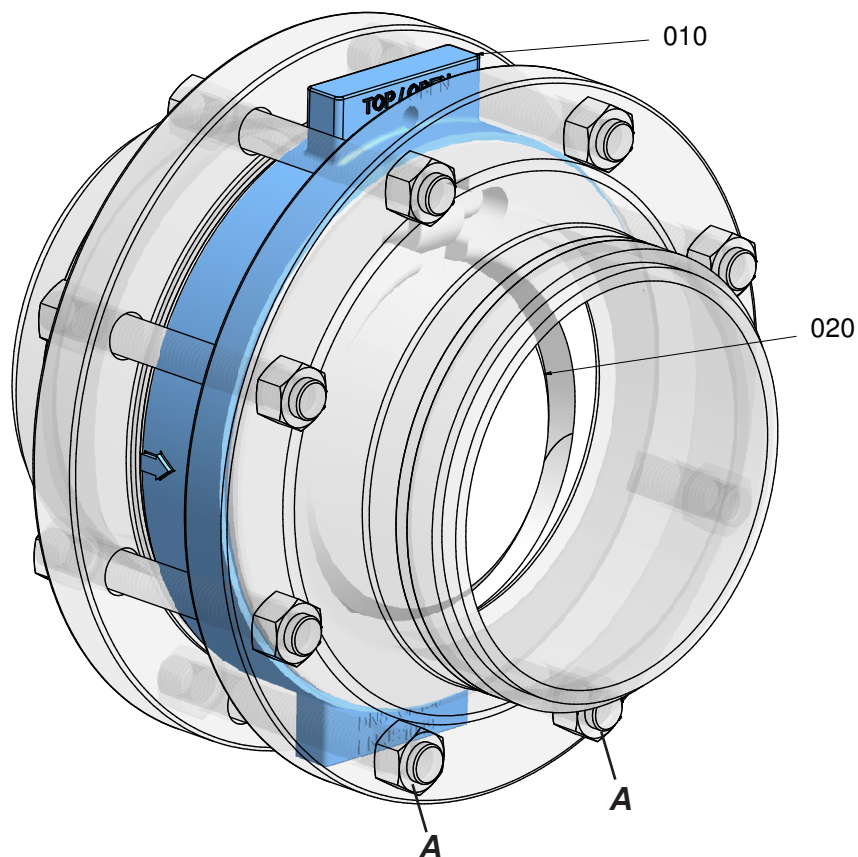

Disassembly Instruction ARK2

For all jobs which are to be carried out on an installed valve, the works safety requirements and the general accident prevention instructions must be observed. Moreover, the general installation and maintenance instructions for atomac fluor-carbon resin lined valves must be considered.

1. Before disassembling the valve it has to be cleaned.
2. Unscrew the hexagon nuts of the pipe connection (**A**) except the lower bolts and remove the studs.
3. Remove the check valve out of the pipe, and make sure that the disc (**020**) is protected.
4. Place the body (**010**) on a rubber mat and remove the disc (**020**).

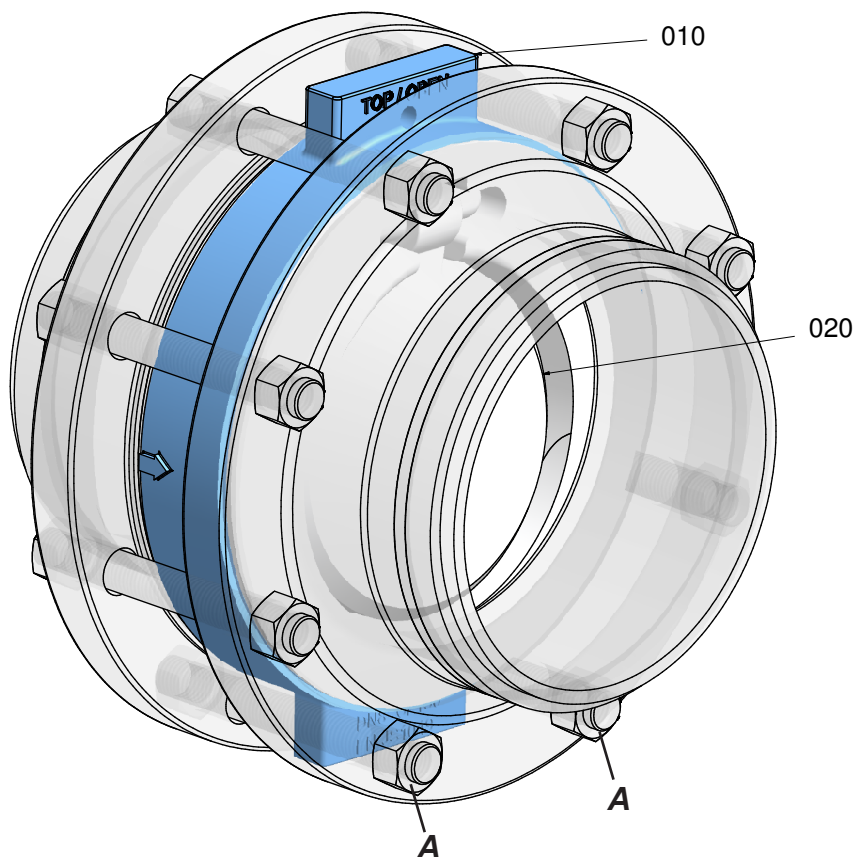

ARK2 - recommended tightening torques*

DN	connection flange	
	Nm	in.lbs
050	68	602
2"	61	540
080	54	478
3"	106	938
100	74	655
4"	80	708
150	147	1301
6"	160	1416
200	146	1292
8"	223	1974
250	225	1991
10"	226	2000
300	277	2452
12"	298	2638
350	275	2434
14"	318	2815
400	359	3177
16"	304	2691

* maximum value

ARK2 - K_v Data and C_v Data (DIN EN 60534-2-3)

DIN	ANSI	K_v m ³ /h	C_v gal/min
050	2"	29,0	33,7
080	3"	75,8	88,1
100	4"	193,0	224,3
150	6"	472,0	548,6
200	8"	875,0	1017,0
250	10"	1410,0	1638,8
300	12"	2380,0	2766,3
350	14"	2670,0	3103,3
400	16"	4630,0	5381,4