

Diaval[®]



Diaphragm Valves
www.diaval.com

Weir Type Diaphragm Valves

Codification

W D 0 0 D I 1 0 D 1 0 0 5 0

BODY DESIGN

W	Weir
S	Straight Through
F	Full Flow

FACE TO FACE/DRILLING

DI10	DIN3202F1 PN10
AS15	BS5156 ASA 150
BS10	BS5156 PN10
0B SPTH	Threaded BSPP

BODY/BONNET MATERIAL

C	Cast iron
D	Ductile iron
A	Carbon steel
S	St. steel 316
I	Chr. iron 24%
J	Chr. iron 30%
B	Bronze
K	St. steel 316L
E	St. steel 304
M	Monel
H	Hastelloy
X	St. steel 1.4435
Y	St. steel 1.4435 BN2

DIAPHRAGM/SEALING

D10	Natural rubber
D15	White natural rubber
D20	EPDM
D2V	EPDM vacuum service
D30	Butyl
D40	NBR
D4V	NBR vacuum service
D50	Neoprene
D60	Hypalon
D70	Viton
D92	PTFE/EPDM
D93	PTFE/Butyl
D97	PTFE/Viton
DLN	Linatex
D9E	Laminated PTFE with EPDM back
D9B	Laminated PTFE with butyl back

BODY BASE MATERIAL

00	Unlined
HR	Hard rubber
SR	Soft rubber
BR	Butyl rubber
ER	EPDM rubber
NL	Neoprene rubber
HY	Hypalon® rubber
PF	PFA
FE	FEP
ET	ETFE
HL	Halar®
LN	Linatex

SIZE

015	DN15
050	DN50
100	DN100

Design Attributes

Weir Type Diaphragm Valves are linear motion valves, bidirectional, for stopping or regulating the flow of the service fluid when necessary. Valves close by turning the handwheel clockwise. Valves are bolted bonnet, seatless design, with a diaphragm as closure element, with rising handwheel. Valves are offered with a broad range of diaphragms and linings materials to resist to abrasion and corrosion duties. The valves are inexpensive and easy to maintain, being the optimal solution for a large number of applications.

Yellow position indicator, for clear and positive valve position from any angle

Nameplate incl. batch no. for full traceability

Closure Diaphragms; manufactured from elastomeric and fluorocarbon materials; provide 100% seating tightness in both directions while isolating the valve trim from fluid. Wide choice of polymers to satisfy any industrial application

Ergonomic and rugged rising handwheel

Grease reservoir integrated in the spindle chamber that lubricates the spindle along operations thus avoiding valve spindle jamming

Witness hole to detect leakage at diaphragm failure

Full rubber flange face in all rubber lined valves as standard

Porousless linings; provides the application engineer with a wide choice of linings of high chemical and abrasion resistance without need of expensive basic metal valve materials

Precise compressor plate; guide and operates the diaphragm up and down



Threaded version

Main Features

Valve design: EN 13397, EN 12516

Face to face length: EN 558 Series 1 (DIN 3202F1) or EN 558 Series 7 (BS 5156)

Valve end connections: - Flanged to EN 1092-2 type 21/B, PN10/16 (DN15-150)*; PN10 (DN200-300)

**(valves DN65 with 4 holes as accepted variant in standard)*

option drilling to ASA150#

- Female threaded ends to ISO 228-1 (DIN 259-BSPP)

Marking: EN 19

Pressure Tests: EN 12266-1

Seat leakage rate: Rate A (full seat tightness in both directions)

Inside and outside primer paint layer black color for protection during storage and transport

Product compliant with Directive 2014/68/EU on Pressure Equipment (PED) and Machinery Directive 2006/42/EC

Options

Other materials, other ratings and connexions, pneumatic or electric actuator, limit switches, sealed bonnet, interlocking arrangement, padlocking or handwheel hood to avoid non-authorized operation. Please consult us

Main Duties / Limits of use

Liquids compatible with materials of construction, acc. to Directive 2014/68/EU Annex II tables 8 (group 1*) & 9 (group 2*) up to category I

Rubber Diaph.

- PS:16 bar DN10-50 (Art.4-Parr.3)
- PS:10 bar DN65-150 (Art.4-Parr.3)
- PS:6 bar DN200 (Art.4-Parr.3)
- PS:5 bar DN250 (Art.4-Parr.3)
- PS:4 bar DN300 (Art.4-Parr.3)

PTFE Diaph.

- PS:10 bar DN10-125 (Art.4-Parr.3)
- PS:6 bar DN150 (Art.4-Parr.3)

Combination of Body + Lining + Diaphragm determines the P-T limit of use of the valve

Questions referring to chemical resistance, please consult us

Observe also pressure/temperature limits on diagrams under

*Classification of fluids (group 1 or 2) acc. to Directive 2014/68/EU, Article 13

Bodies (Ductile iron)

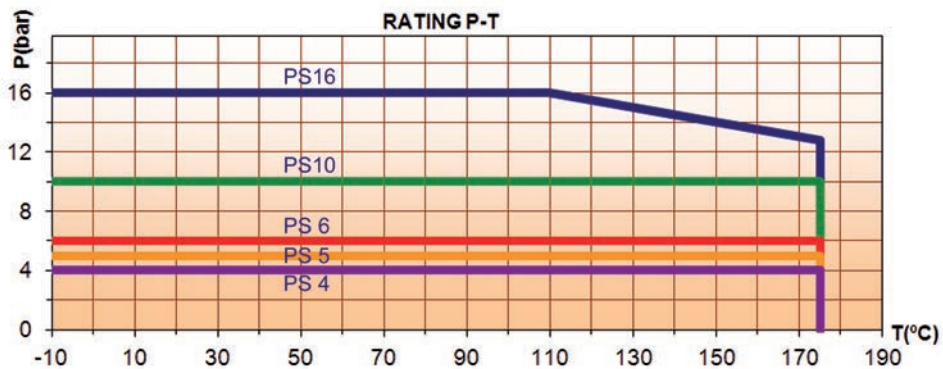

Linings

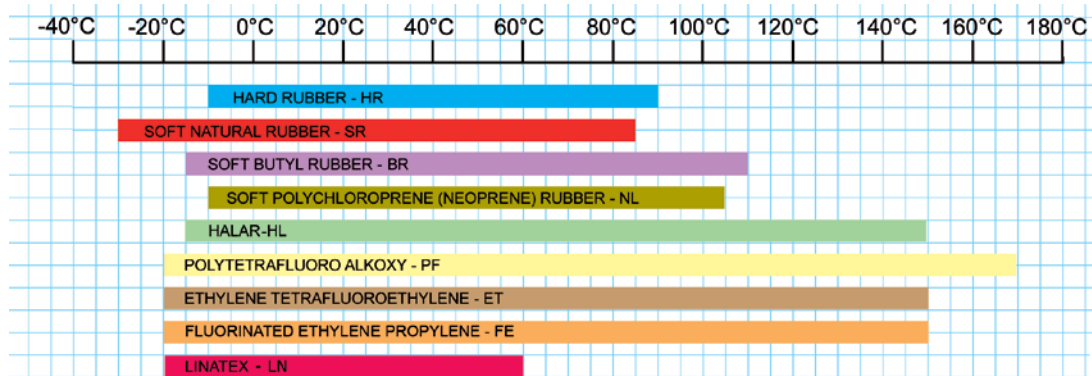

Diaphragms

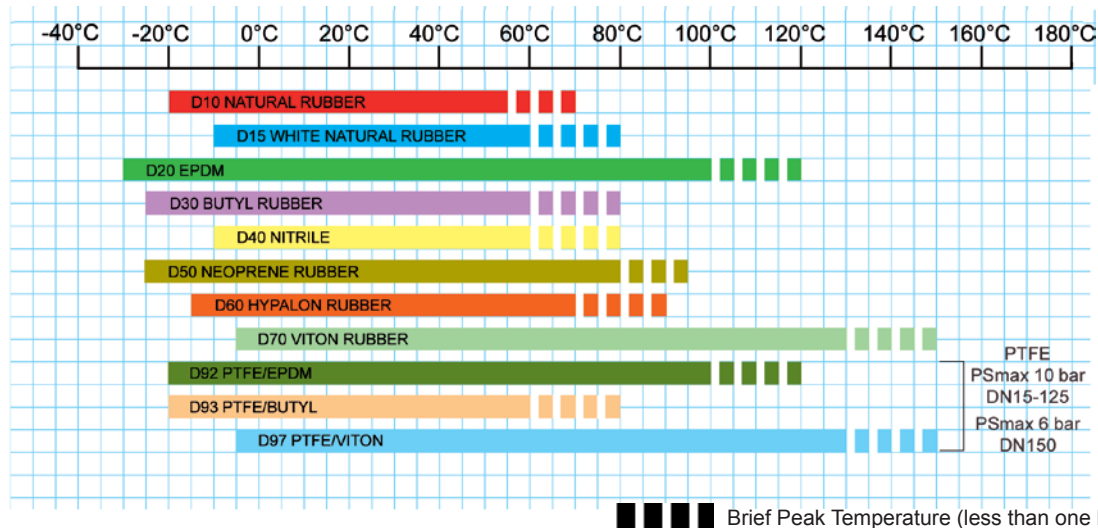

Temperature Values are for neutral fluids and not plotted against any pressure parameter, the application engineer should consider that working limits are affected by the actual pressure / temperature relationship. Temperature values also depends on medium through the valve.

Valves Flow Data

A valve flow coefficient represents the standard flow rate which flows through the valve at a given opening, referred to pre-established conditions:

* Kv value is the volume of water at 20°C, in cubic meters per hour (m³/h), that will flow through the valve at a static pressure drop of 1 bar across the valve

* Cv value is the volume of water at 60°F, in gallons per minute (gpm), that will flow through the valve at a static pressure drop of 1 psi across the valve

Conversion from Kv to Cv can be roughly calculated by means of the following expression:

$$Cv = Kv \times 1,17$$

Flow rate through the valve with other liquids can be calculated with the following expressions

$$Kv = q (SG / dp)^{1/2}$$

where

q = water flow (cubic meter per hour)

SG = specific gravity (1 for water)

dp = pressure drop (bar)

$$Cv = q (SG / dp)^{1/2}$$

where

q = water flow (US gallons per minute)

SG = specific gravity (1 for water)

dp = pressure drop (psi)

How to use the graphs:

The flow graphs in the following sheets provide the valve flow rate across the valve body at a determine opening degree.

Choose the graph heading the valve Nominal Diameter which is being looked for; consider the valve inner lining features from a choice of unlined, rubber lined, ECTFE (Halar) lined or Fluoropolymer coated valve bodies and plot an intersection line upwards from the opening degree (in case of throttling) or full open to the colour representing the lining. The vertical axis will give the Kv value expressed in M³/h.

Flow Coefficients Kv (m³/h)

Weir Type DN15

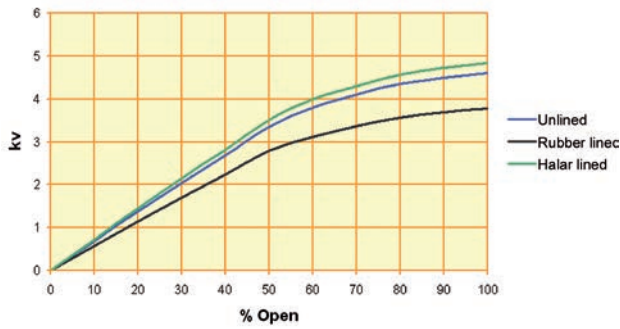

Weir Type DN20

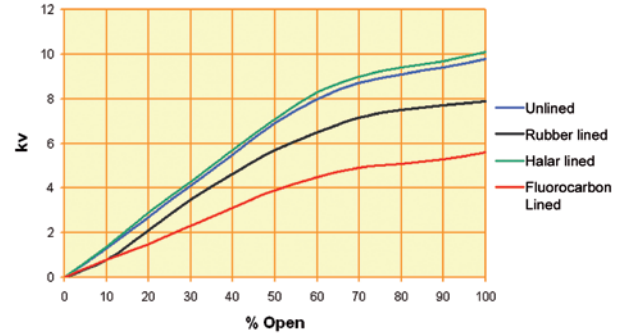

Weir Type DN25

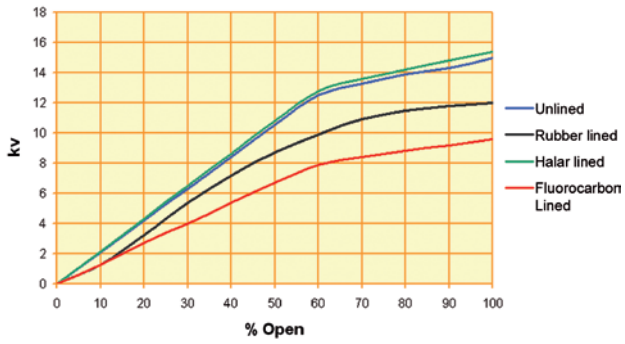

Weir Type DN32

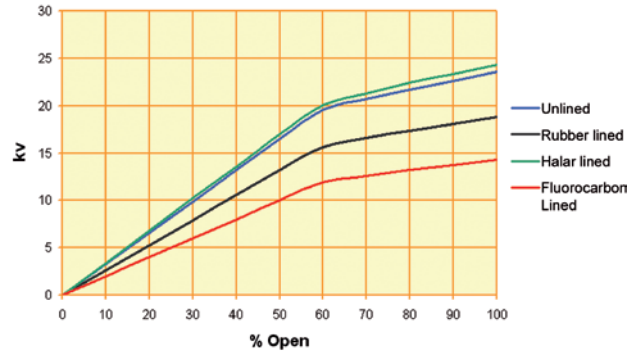

Weir Type DN40

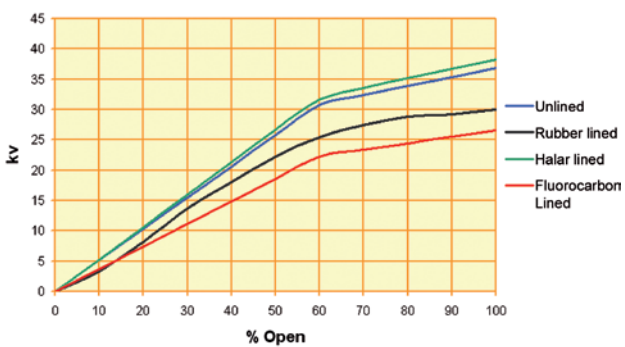

Weir Type DN50

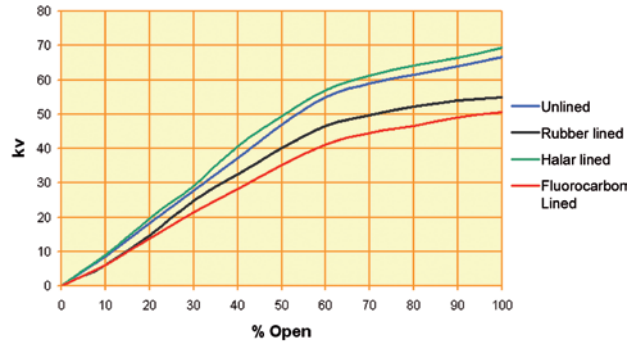

Weir Type DN65

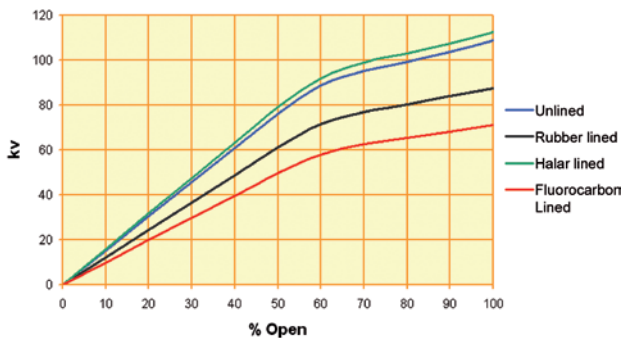

Weir Type DN80

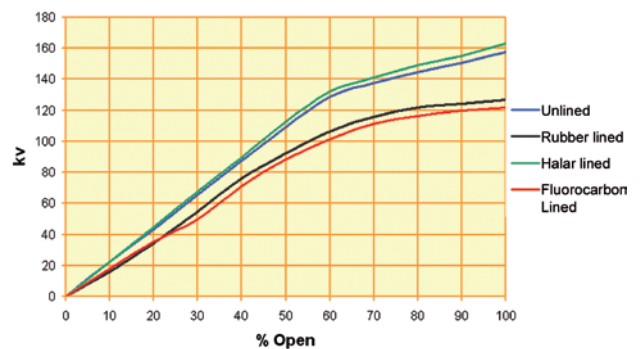

Flow Coefficients Kv (m³/h)

Weir Type DN100

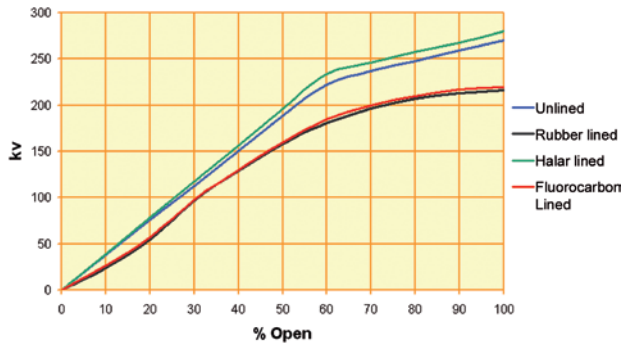

Weir Type DN125

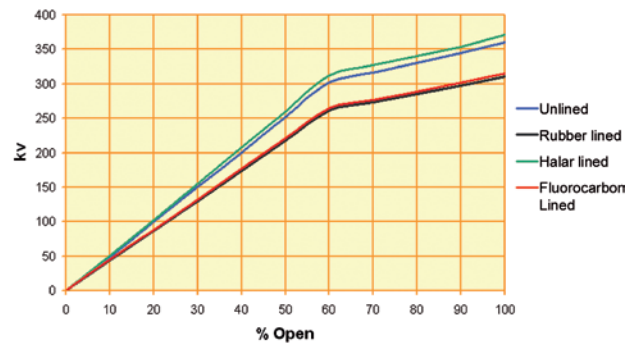

Weir Type DN150

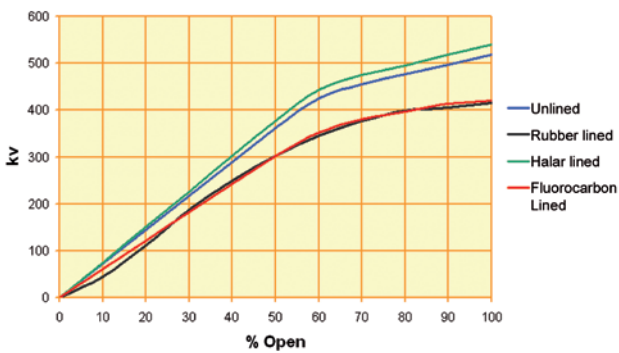

Weir Type DN200

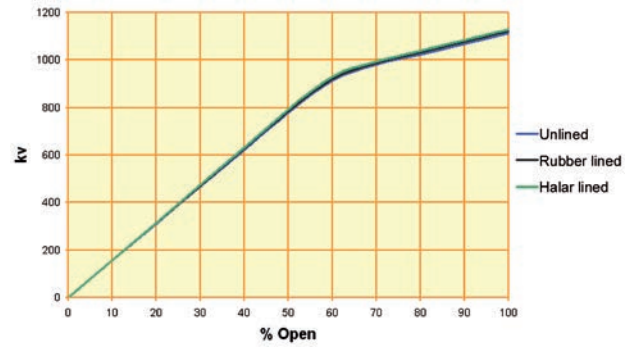

Weir Type DN250

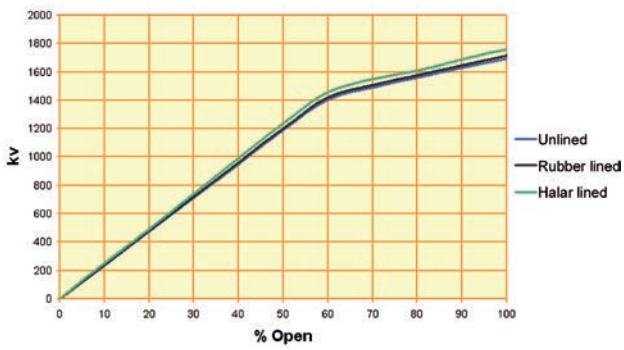

Weir Type DN300

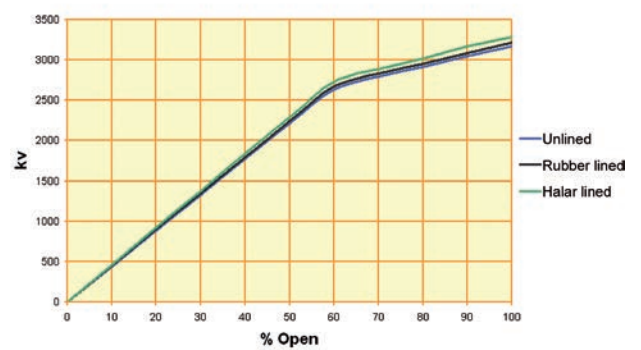

Unlined valves with flanged ends

Main Parts and Materials

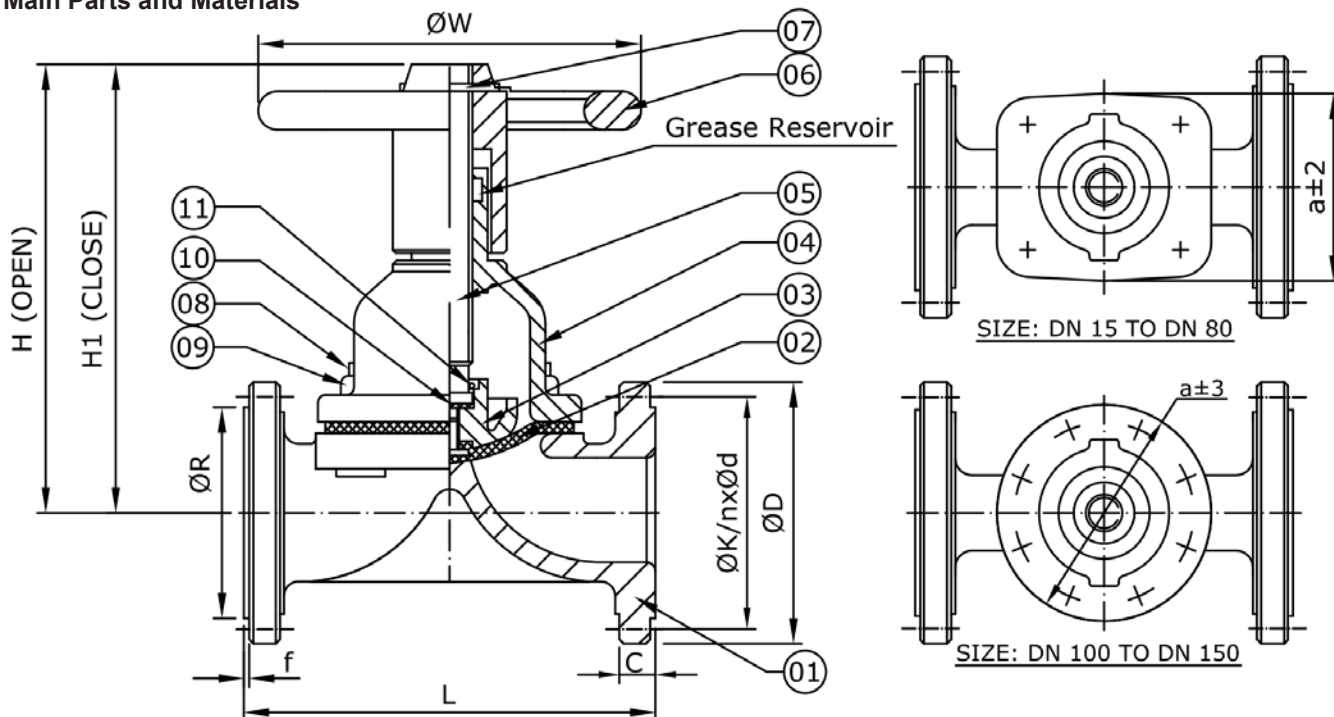

NO.	PART	MATERIAL
1	BODY	WC_ Cast iron EN-JL 1040 (GG25)
		WD_ Ductile iron EN-JS1030 (GGG40)
2	DIAPHRAGM	RUBBER Natural (D10) / EPDM (D20) / Butyl (D30) / Nitrile (D40) / Neoprene (D50) / Hypalon (D60) / Viton (D70)
		PTFE + EPDM (D92) / PTFE + Butyl (D93) / PTFE + Viton (D97)
3	COMPRESSOR	Cast iron EN-JL1040 (GG25)
4	BONNET	WC_ Cast iron EN-JL 1040 (GG25)
		WD_ Ductile iron EN-JS1030 (GGG40)

NO.	PART	MATERIAL
5	SPINDLE	Steel
6	HANDWHEEL	Cast iron EN-JL 1040 (GG25)
7	H/W DOWEL PIN	Steel (EN42)
8	BODY STUDS	Steel
9	BODY NUTS	Steel
10	THRUST WASHER	Nylon
11	COMP. PIN	Steel (EN42)

Main Valve Parameters

	DN	15	20	25	32	40	50	65
L	EN 558 S7 (BS 5156)	108	114	127	146	159	190	216
	EN 558 S1 (DIN 3202 F1)	130	150	160	180	200	230	290
	H (open)	109	117	140	143	172	190	230
	H1 (close)	103	109	130	131	152	166	195
	a	52	67	75	88	110	127	146
	ØW	100	100	120	120	120	164	220
FLANGED ENDS TO EN PN10	ØD	95	105	115	140	150	165	185
	C	14	16	16	18	18	20	20
	ØR	45	58	68	78	88	102	122
	f	2	2	2	2	3	3	3
	nxØd	4x14	4x14	4x14	4x18	4x18	4x18	4x18
	ØK	65	75	85	100	110	125	145
FLANGED ENDS TO ASA150#*	ØD	89	98	108	117	127	152	178
	C	11,5	11,5	11,5	13	14,5	16	17,5
	ØR	35	43	51	64	73	92	105
	f	1,6	1,6	1,6	1,6	1,6	1,6	1,6
	nxØd	4x16	4x16	4x16	4x16	4x16	4x19	4x19
	ØK	60,3	69,8	79,4	88,9	98,4	120,6	139,7
Approx. Weight	EN 558 S7 (BS 5156)	2,3	3,2	4,2	6,4	7,5	12	18
	EN 558 S1 (DIN 3202 F1)	2,7	3,5	4,4	6,6	8,5	12,5	19

*Unless specific agreement with COMEVAL, valves with flanges 150# will be usually supplied as EN/DIN flanges with 150# drilling, since pressure is limited to EN/DIN

Dimensions in mm subject to manufacturing tolerance / Weights in kg

Information / restriction of technical rules need to be observed!
Installation, Operating and Maintenance Manual can be downloaded at www.comeval.es

The engineer, designing a system or a plant, is responsible for the selection of the correct valve
Product suitability must be verified, contact manufacturer for information

Unlined valves with flanged ends

Main Valve Parameters

DN		80	100	125	150	200	250	300
L	EN 558 S7 (BS 5156)	254	305	356	406	521	635	749
	EN 558 S1 (DIN 3202 F1)	310	350	400	480	600	730	850
H (open)		242	326	391	468	680	802	971
H1 (close)		202	275	326	390	560	657	796
a		190	Ø230	Ø265	Ø320	Ø420	Ø502	Ø569
ØW		240	270	270	360	460	600	700
FLANGED ENDS TO EN PN10	ØD	200	220	250	285	340	395	445
	C	22	24	26	26	26	28	28
	ØR	138	158	188	212	268	320	370
	f	3	3	3	3	3	3	4
	nxØd	8x18	8x18	8x18	8x22	8x22	12x22	12x22
FLANGED ENDS TO ASA150#*	ØK	160	180	210	240	295	350	400
	ØD	191	229	254	279	343	406	483
	C	19,5	24	24	25,5	29	30,5	32
	ØR	127	157	186	216	270	324	381
	f	1,6	1,6	1,6	1,6	1,6	1,6	1,6
	nxØd	4x19	8x19	8x22	8x22	8x22	12x22	12x22
ØK	152,4	190,5	215,9	241,3	298,4	361,9	431,8	
Approx. Weight	EN 558 S7 (BS 5156)	23	34	50	69	150	220	300
	EN 558 S1 (DIN 3202 F1)	25	36	52	75	160	235	315

*Unless specific agreement with COMEVAL, valves with flanges 150# will be usually supplied as EN/DIN flanges with 150# drilling, since pressure is limited to EN/DIN

Dimensions in mm subject to manufacturing tolerance / Weights in kg

Rubber lined valves with flanged ends

Main Parts and Materials

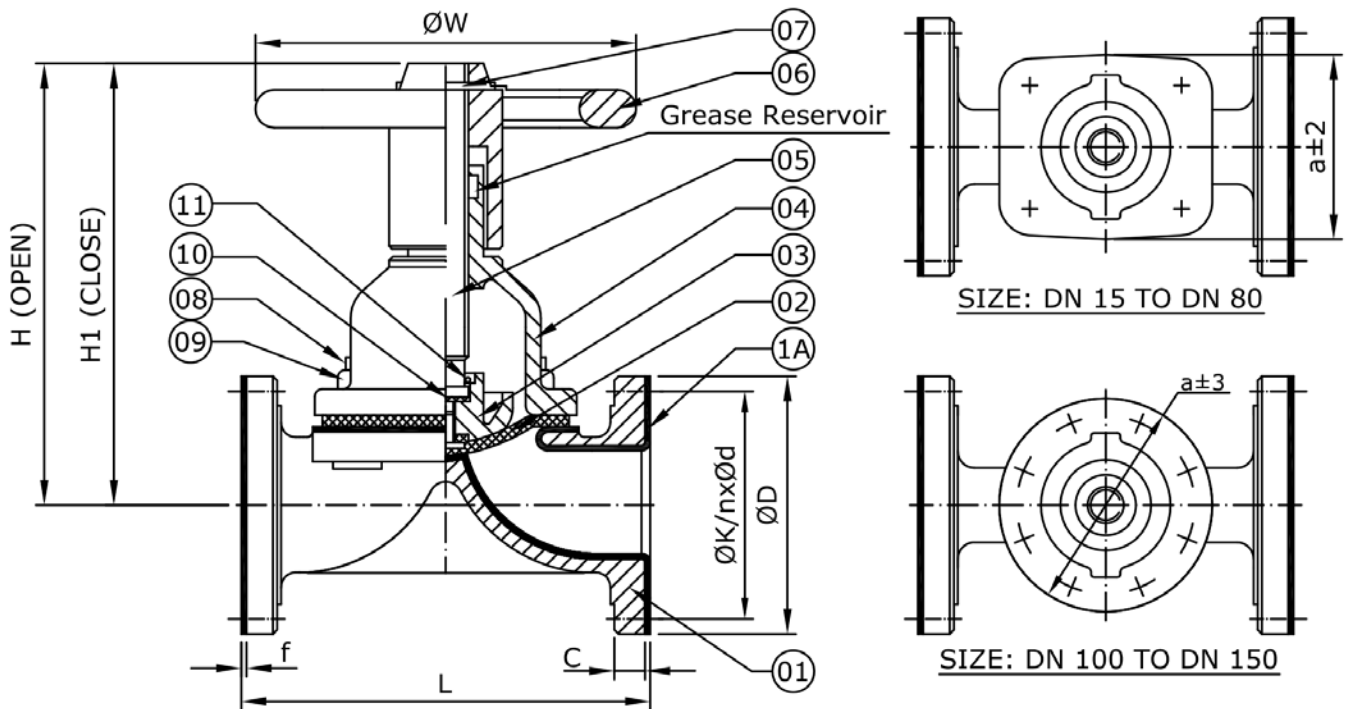

NO.	PART	MATERIAL	NO.	PART	MATERIAL
1	BODY	WC_ Cast iron EN-JL1040 (GG25)	3	COMPRESSOR	Cast iron EN-JL1040 (GG25)
		WD_ Ductile iron EN-JS1030 (GGG40)	4	BONNET	WC_ Cast iron EN-JL1040 (GG25) WD_ Ductile iron EN-JS1030 (GGG40)
	HR	Hard rubber	5	SPINDLE	Steel
	SR	Soft rubber	6	HANDWHEEL	Cast iron EN-JL1040 (GG25)
	1A	LINING	_BR_ Butyl rubber	7	H/W DOWEL PIN
		ER EPDM rubber	8	BODY STUDS	Steel
		NL Neoprene rubber	9	BODY NUTS	Steel
2	DIAPHRAGM + BACKING	RUBBER Natural (D10) / EPDM (D20) / Butyl (D30) / Nitrile (D40) / Neoprene (D50) / Hypalon (D60) / Viton (D70)	10	THRUST WASHER	Nylon
		PTFE + EPDM (D92) / PTFE + Butyl (D93) / PTFE + Viton (D97)	11	COMP. PIN	Steel (EN42)

Main Valve Parameters

	DN	15	20	25	32	40	50	65
L	EN 558 S7 (BS 5156)	114	123	133	152	165	196	222
	EN 558 S1 (DIN 3202 F1)	130	150	160	180	200	230	290
	H (open)	112	120	143	145	175	193	233
	H1 (close)	106	112	133	134	155	169	198
	f	3	3	3	3	3	3	3
	a	52	67	75	88	110	127	146
	ØW	100	100	120	120	120	164	220
FLANGED ENDS TO EN PN10	ØD	95	105	115	140	150	165	185
	C	14	16	16	18	18	20	20
	nxØd	4x14	4x14	4x14	4x18	4x18	4x18	4x18
	ØK	65	75	85	100	110	125	145
FLANGED ENDS TO ASA150**	ØD	89	98	108	117	127	152	178
	C	11,5	11,5	11,5	13	14,5	16	17,5
	nxØd	4x16	4x16	4x16	4x16	4x16	4x19	4x19
	ØK	60,3	69,8	79,4	88,9	98,4	120,6	139,7
Approx. Weight	EN 558 S7 (BS 5156)	3,2	3,4	4,7	7	8,5	12	22
	EN 558 S1 (DIN 3202 F1)	3,5	3,7	5	8,2	9,5	13,3	22,5

*Unless specific agreement with COMEVAL, valves with flanges 150# will be usually supplied as EN/DIN flanges with 150# drilling, since pressure is limited to EN/DIN

Dimensions in mm subject to manufacturing tolerance / Weights in kg

Information / restriction of technical rules need to be observed!
Installation, Operating and Maintenance Manual can be downloaded at www.comeval.es

The engineer, designing a system or a plant, is responsible for the selection of the correct valve
Product suitability must be verified, contact manufacturer for information

Rubber lined valves with flanged ends

Main Valve Parameters

DN		80	100	125	150	200	250	300
L	EN 558 S7 (BS 5156)	260	313	364	414	529	643	757
	EN 558 S1 (DIN 3202 F1)	310	350	400	480	600	730	850
	H (open)	245	330	395	472	684	806	975
	H1 (close)	205	279	330	394	564	661	800
f		3	4	4	4	4	4	4
a		190	Ø230	Ø265	Ø320	Ø420	Ø502	Ø569
ØW		240	270	270	360	460	600	700
FLANGED ENDS TO EN PN10	ØD	200	220	250	285	340	395	445
	C	22	24	26	26	26	28	28
	nxØd	8x18	8x18	8x18	8x22	8x22	12x22	12x22
	ØK	160	180	210	240	295	350	400
FLANGED ENDS TO ASA150#*	ØD	191	229	254	279	343	406	483
	C	19,5	24	24	25,5	29	30,5	32
	nxØd	4x19	8x19	8x22	8x22	8x22	12x26	12x26
	ØK	152,4	190,5	215,9	241,3	298,4	361,9	431,8
Approx. Weight	EN 558 S7 (BS 5156)	26	38	54	76	155	227	307
	EN 558 S1 (DIN 3202 F1)	28,5	40	57	81	165	242	322

*Unless specific agreement with COMEVAL, valves with flanges 150# will be usually supplied as EN/DIN flanges with 150# drilling, since pressure is limited to EN/DIN

Dimensions in mm subject to manufacturing tolerance / Weights in kg

Fluoropolymer lined valves with flanged ends

Main Parts and Materials

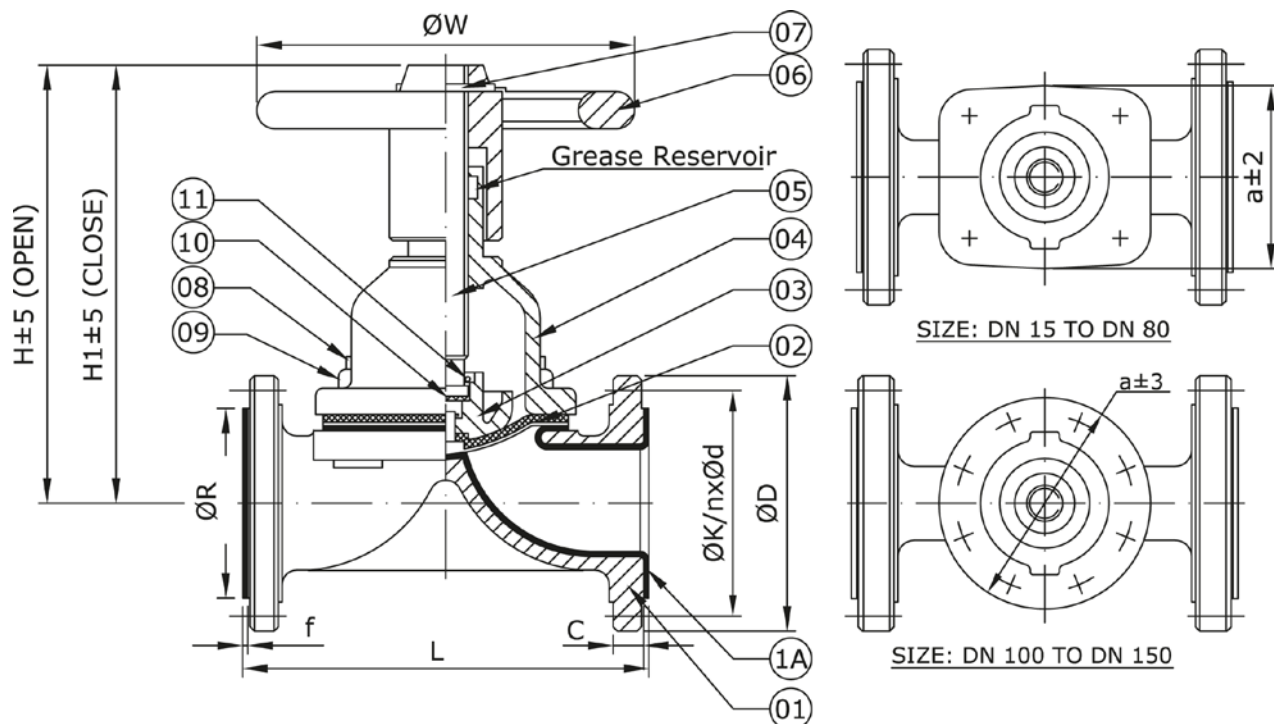

NO.	PART	MATERIAL	NO.	PART	MATERIAL	
1	BODY	Ductile iron EN-JS1030 (GGG40) / EN-JS1049 (GGG40.3)	4	BONNET	Ductile iron EN-JS1030 (GGG40) / EN-JS1049 (GGG40.3)	
1A	LINING	PF	PFA	5	SPINDLE	Steel
		FE	FEP	6	HANDWHEEL	Cast iron EN-JL1040 (GG25)
		ET	ETFE	7	H/W DOWEL PIN	Steel (EN42)
2	DIAPHRAGM + BACKING	RUBBER	Natural (D10) / EPDM (D20) / Butyl (D30) / Nitrile (D40) / Neoprene (D50) / Hypalon (D60) / Viton (D70)	8	BODY STUDS	Stainless steel SS304
			PTFE + EPDM (D92) / PTFE + Butyl (D93) / PTFE + Viton (D97)	9	BODY NUTS	Stainless steel SS304
3	COMPRESSOR	Cast iron EN-JL1040 (GG25)	10	THRUST WASHER	Nylon	
			11	COMP. PIN	Steel (EN42)	

Main Valve Parameters

	DN	15	20	25	32	40
L	EN 558 S7 (BS 5156)	114	123	133	152	165
	EN 558 S1 (DIN 3202 F1)	130	150	160	180	200
	H (open)	109	120	149	162	175
	H1 (close)	103	112	139	151	155
	f	3	3	3	3	3
	a	52	67	75	88	110
	ØW	100	100	120	120	120
FLANGED ENDS TO EN PN10	ØD	95	105	115	140	150
	C	14	16	16	18	18
	ØR	45	58	68	78	88
	nxØd	4x14	4x14	4x14	4x18	4x18
	ØK	65	75	85	100	110
FLANGED ENDS TO ASA150#	ØD	89	98	108	117	127
	C	11,5	11,5	11,5	13	14,5
	ØR	35	43	51	64	73
	nxØd	4x16	4x16	4x16	4x16	4x16
	ØK	60,3	69,8	79,4	88,9	98,4
Approx. Weight	EN 558 S7 (BS 5156)	3,2	3,4	4,7	7	8,5
	EN 558 S1 (DIN 3202 F1)	3,5	3,7	5	8,2	9,5

*Unless specific agreement with COMEVAL, valves with flanges 150# will be usually supplied as EN/DIN flanges with 150# drilling, since pressure is limited to EN/DIN

Dimensions in mm subject to manufacturing tolerance / Weights in kg

Information / restriction of technical rules need to be observed!

The engineer, designing a system or a plant, is responsible for the selection of the correct valve Product suitability must be verified, contact manufacturer for information

Installation, Operating and Maintenance Manual can be downloaded at www.comeval.es

Fluoropolymer lined valves with flanged ends

Main Valve Parameters

DN		50	65	80	100	125	150
L	EN 558 S7 (BS 5156)	196	222	260	313	364	414
	EN 558 S1 (DIN 3202 F1)	230	290	310	350	400	480
	H (open)	190	253	243	327	392	462
	H1 (close)	166	218	203	276	328	384
	f	3	3	3	4	4	4
	a	127	146	190	Ø230	Ø265	Ø320
	ØW	164	220	240	270	270	360
FLANGED ENDS TO EN PN10	ØD	165	185	200	220	250	285
	C	20	20	22	24	26	26
	ØR	102	122	138	158	188	212
	nxØd	4x18	4x18	8x18	8x18	8x18	8x22
FLANGED ENDS TO ASA150#*	ØK	125	145	160	180	210	240
	ØD	152	178	191	229	254	279
	C	16	17,5	19,5	24	24	25,5
	ØR	92	105	127	157	186	216
	nxØd	4x19	4x19	4x19	8x19	8x22	8x22
	ØK	120,6	139,7	152,4	190,5	215,9	241,3
Approx. Weight	EN 558 S7 (BS 5156)	12	22	26	38	54	76
	EN 558 S1 (DIN 3202 F1)	13,3	22,5	28,5	40	57	81

*Unless specific agreement with COMEVAL, valves with flanges 150# will be usually supplied as EN/DIN flanges with 150# drilling, since pressure is limited to EN/DIN

Dimensions in mm subject to manufacturing tolerance / Weights in kg

Halar® coated valves with flanged ends

Main Parts and Materials

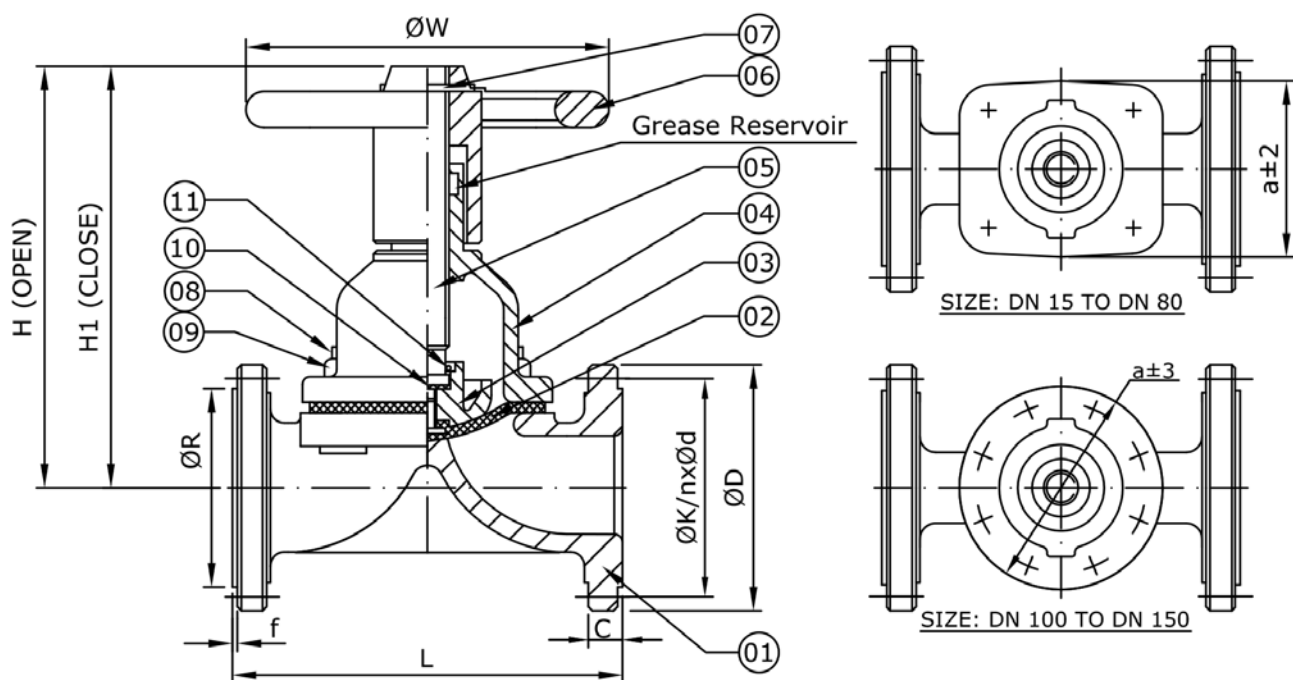

NO.	PART	MATERIAL
1	BODY	WCHL_ Cast iron EN-JL1040 (GG25)
		WDHL_ Ductile iron EN-JS1030 (GGG40)
2	DIAPHRAGM	RUBBER Natural (D10) / EPDM (D20) / Butyl (D30) / Nitrile (D40) / Neoprene (D50) / Hypalon (D60) / Viton (D70)
		PTFE + EPDM (D92) / PTFE + Butyl (D93) / PTFE + Viton (D97)
3	COMPRESSOR	Cast iron EN-JL1040 (GG25)
4	BONNET	WCHL_ Cast iron EN-JL1040 (GG25)
		WDHL_ Ductile iron EN-JS1030 (GGG40)

NO.	PART	MATERIAL
5	SPINDLE	Steel
6	HANDWHEEL	Cast iron EN-JL1040 (GG25)
7	H/W DOWEL PIN	Steel (EN42)
8	BODY STUDS	St. steel SS304
9	BODY NUTS	St. steel SS304
10	THRUST WASHER	Nylon
11	COMP. PIN	Steel (EN42)

Main Valve Parameters

	DN	15	20	25	32	40
L	EN 558 S7 (BS 5156)	108	114	127	146	159
	EN 558 S1 (DIN 3202 F1)	130	150	160	180	200
	H (open)	109	117	140	143	172
	H1 (close)	103	109	130	131	152
	a	52	67	75	88	110
	ØW	100	100	120	120	120
FLANGED ENDS TO EN PN10	ØD	95	105	115	140	150
	C	14	16	16	18	18
	ØR	45	58	68	78	88
	f	2	2	2	2	3
	nxØd	4x14	4x14	4x14	4x18	4x18
	ØK	65	75	85	100	110
FLANGED ENDS TO ASA150#*	ØD	89	98	108	117	127
	C	11,5	11,5	11,5	13	14,5
	ØR	35	43	51	64	73
	f	1,6	1,6	1,6	1,6	1,6
	nxØd	4x16	4x16	4x16	4x16	4x16
	ØK	60,3	69,8	79,4	88,9	98,4
Approx. Weight	EN 558 S7 (BS 5156)	2,3	3,2	4,2	6,4	7,5
	EN 558 S1 (DIN 3202 F1)	2,7	3,5	4,4	6,6	8,5

*Unless specific agreement with COMEVAL, valves with flanges 150# will be usually supplied as EN/DIN flanges with 150# drilling, since pressure is limited to EN/DIN Information / restriction of technical rules need to be observed! Installation, Operating and Maintenance Manual can be downloaded at www.comeval.es

Dimensions in mm subject to manufacturing tolerance / Weights in kg

The engineer, designing a system or a plant, is responsible for the selection of the correct valve Product suitability must be verified, contact manufacturer for information

Halar® coated valves with flanged ends

Main Valve Parameters

	DN	50	65	80	100	125	150
L	EN 558 S7 (BS 5156)	190	216	254	305	356	406
	EN 558 S1 (DIN 3202 F1)	230	290	310	350	400	480
	H (open)	190	230	242	326	391	468
	H1 (close)	166	195	202	275	326	390
	a	127	146	190	Ø230	Ø265	Ø320
	ØW	164	220	240	270	270	360
FLANGED ENDS TO EN PN10	ØD	165	185	200	220	250	285
	C	20	20	22	24	26	26
	ØR	102	122	138	158	188	212
	f	3	3	3	3	3	3
	nxØd	4x18	4x18	8x18	8x18	8x18	8x22
FLANGED ENDS TO ASA150#*	ØK	125	145	160	180	210	240
	ØD	152	178	191	229	254	279
	C	16	17,5	19,5	24	24	25,5
	ØR	92	105	127	157	186	216
	f	1,6	1,6	1,6	1,6	1,6	1,6
	nxØd	4x19	4x19	4x19	8x19	8x22	8x22
	ØK	120,6	139,7	152,4	190,5	215,9	241,3
Approx. Weight	EN 558 S7 (BS 5156)	12	18	23	34	50	69
	EN 558 S1 (DIN 3202 F1)	12,5	19	25	36	52	75

*Unless specific agreement with COMEVAL, valves with flanges 150# will be usually supplied as EN/DIN flanges with 150# drilling, since pressure is limited to EN/DIN

Dimensions in mm subject to manufacturing tolerance / Weights in kg

Unlined threaded valves

Main Parts and Materials

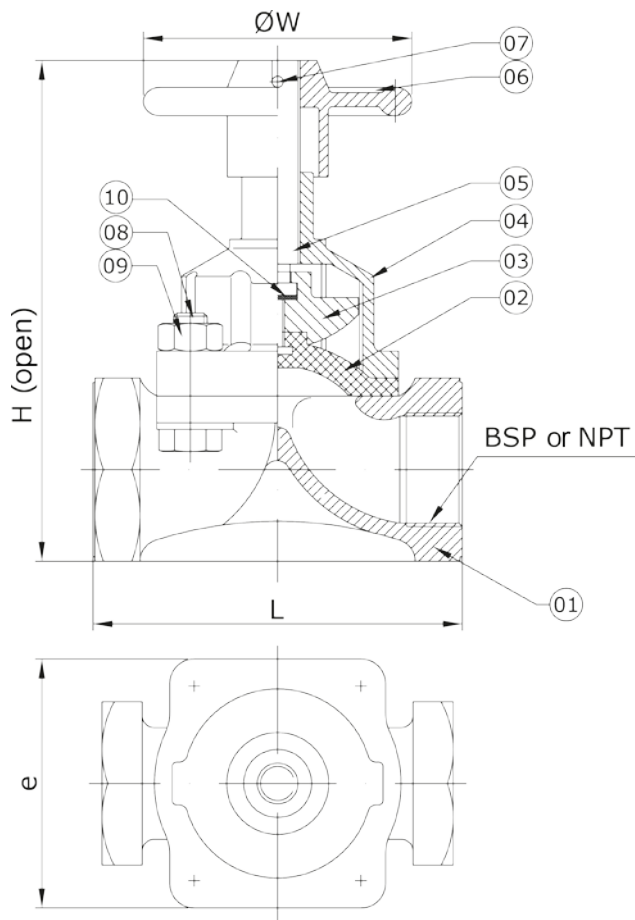

NO.	PART	MATERIAL
1	BODY	WC_ Cast iron EN-JL1040 (GG25)
		WD_ Ductile iron EN-JS1030 (GGG40)
		WS_ St. steel
2	DIAPHRAGM	Natural (D10) / EPDM (D20) / Butyl (D30) / Nitrile (D40) / Neoprene (D50) / Hypalon (D60) / Viton (D70) PTFE + EPDM (D92) / PTFE + Butyl (D93) / PTFE + Viton (D97)
3	COMPRESSOR	Cast iron EN-JL1040 (GG25)
4	BONNET	WC_ Cast iron EN-JL1040 (GG25)
		WD_ Ductile iron EN-JS1030 (GGG40)
		WS_ St. steel
5	SPINDLE	Steel
6	HANDWHEEL	Cast iron EN-JL1040 (GG25)
7	H/W DOWEL PIN	Steel (EN42)
8	BODY STUDS	Steel
9	BODY NUTS	Steel
10	THRUST WASHER	Nylon

Main Valve Parameters

DN		10	15	20	25	32	40	50	65	80
L	(1)	50	66	85	110	124	140	165	203	254
	(2)	-	108	117	127	146	159	190	-	-
H (open)	(1)	70	70	105	122	148	155	183	212	256
	(2)	-	106	117	141	152	176	196	-	-
ØW	(1)	45	75	75	85	120	120	120	165	230
	(2)	-	100	100	120	120	120	164	-	-
e		42	52	67	75	88	110	127	146	190
Approx. Weight		1,2	1,5	2	3,2	4	6	8	11	18

(1) Standard dimensions for cast and ductile iron valves
 (2) Standard dimensions for st. steel valves

Dimensions in mm subject to manufacturing tolerance / Weights in kg

Main Bonnet Dimensions

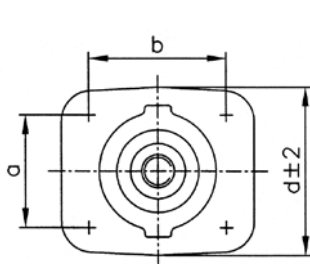
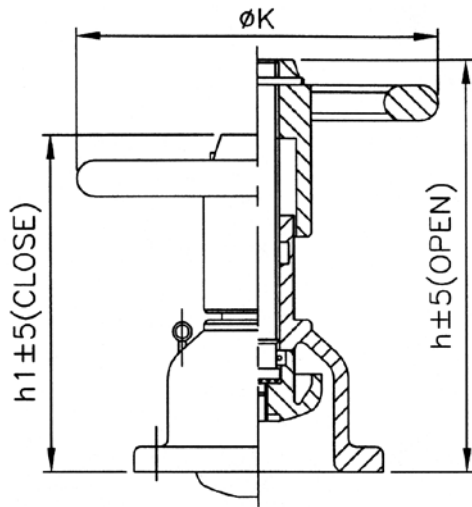

SIZE: DN 15 TO DN 80

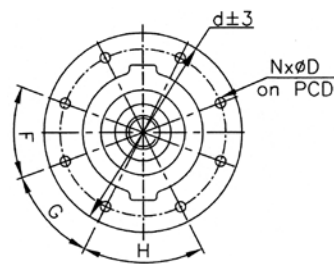

SIZE: DN 100&125

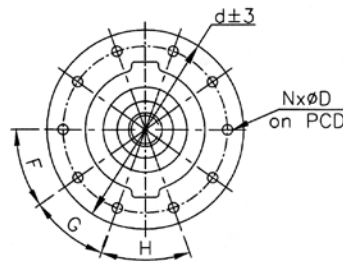

SIZE: DN 150

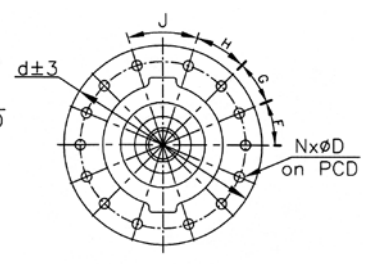

SIZE: DN 200 TO DN 300

DN	a	b ØPCD	d	h	h1	ØK	NxØD	Weight	ANGLES BETWEEN THE HOLES			
									F	G	H	J
15	33	37	52	84	78	100	4x6,5	0,9	---	---	---	---
20	40	44	67	90	82	100	4x7	1,1	---	---	---	---
25	46	54	75	115	105	120	4x9	2,0	---	---	---	---
32	60	67	88	117	106	120	4x9	2,0	---	---	---	---
40	65	70	110	133	113	120	4x11	2,5	---	---	---	---
50	78	83	127	155	131	164	4x11	4,5	---	---	---	---
65	95	102	146	194	159	220	4x13	8,5	---	---	---	---
80	114	127	190	201	161	240	4x16,5	9,5	---	---	---	---
100		Ø194	Ø230	258	207	270	8x13	14,5	40°	42°	56°	---
125		Ø222	Ø265	307	243	270	8x16,5	18,5	43°20'	43°20'	50°	---
150		Ø273	Ø320	358	280	360	10x16	27,0	35°	35°	40°	---
200		Ø381	Ø420	549	429	460	14x16	63,0	22°30'	22°30'	27°	36°
250		Ø438	Ø502	697	552	600	14x21	90,0	22°30'	22°30'	22°30'	45°
300		Ø508	Ø569	804	629	700	14x21	147,0	24°	24°	24°	36°

Dimensions in mm subject to manufacturing tolerance / Weights in kg

Main Spare Diaphragms Dimensions

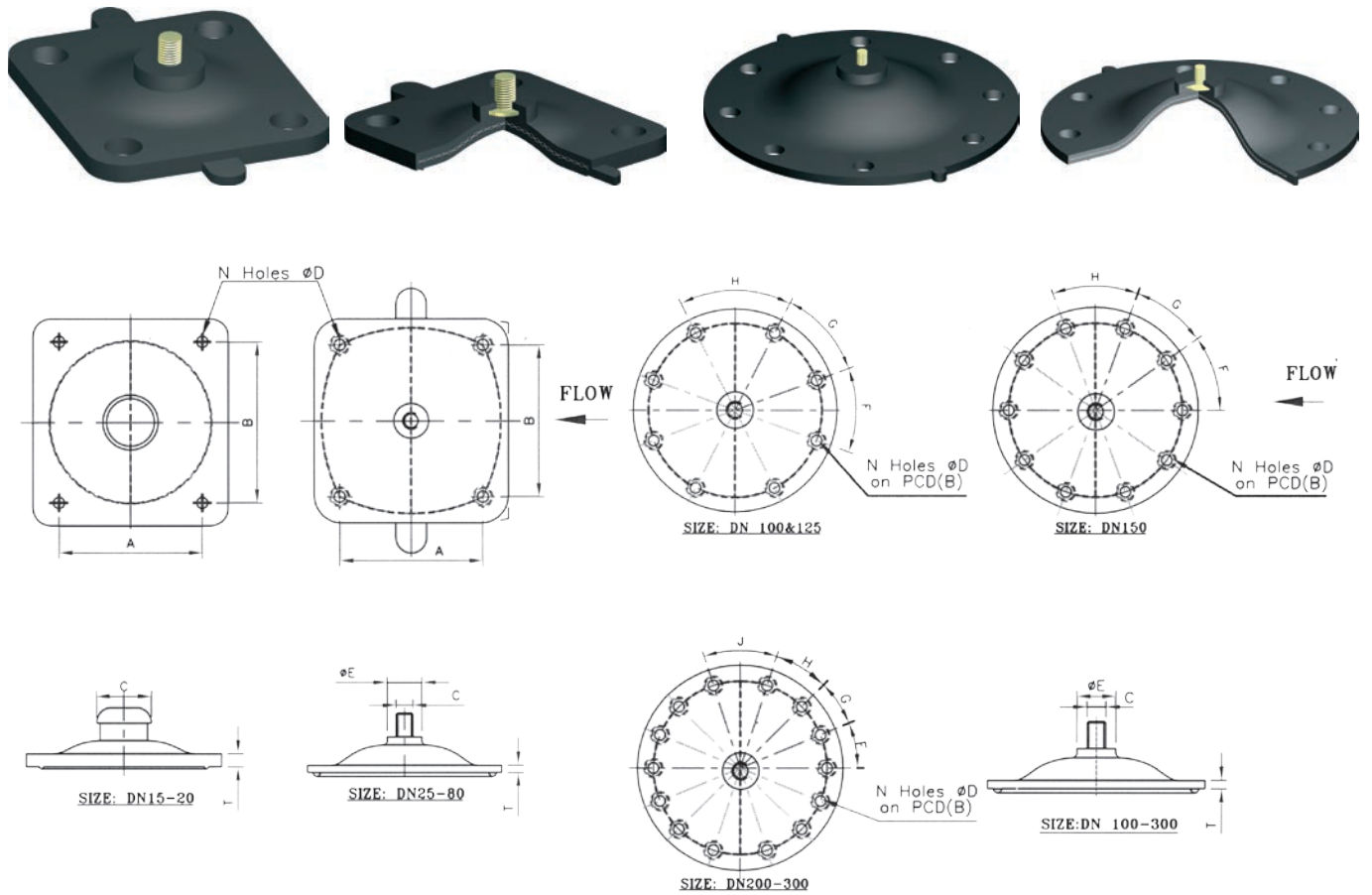

DN	DIMENSIONS OF DIAPHRAGM						ANGLES BETWEEN THE HOLES				
	A	B	C	ØE	ØD	N° HOLES	T	F	G	H	J
15	33	37	Ø12.7	---	7.0	4	6.0	---	---	---	---
20	40	44	Ø12.7	---	8.5	4	6.5	---	---	---	---
25	46	54	1/4" BSW	18.0	9.5	4	6.15	---	---	---	---
32	60	67	1/4" BSW	18.0	10.0	4	7.5	---	---	---	---
40	65	70	1/4" BSW	22.2	11.5	4	7.5	---	---	---	---
50	78	83	1/4" BSW	25.6	11.5	4	7.5	---	---	---	---
65	95	102	5/16" BSW	29.0	14.0	4	7.5	---	---	---	---
80	114	127	5/16" BSW	32.0	18.0	4	8.0	---	---	---	---
100		Ø194	5/16" BSW	37.0	16.0	8	10.0	40°	42°	56°	---
125		Ø222	3/8" BSW	44.5	17.3	8	11.5	43°20'	43°20'	50°	---
150		Ø273	3/8" BSW	50.0	18.5	10	11.5	35°	35°	40°	---
200		Ø381	7/8" BSW	63.0	20.0	14	10.0	22°30'	22°30'	27°	36°
250		Ø438	7/8" BSW	76.0	22.0	14	14.0	22°30'	22°30'	22°30'	45°
300		Ø508	7/8" BSW	89.0	25.0	14	15.5	24°	24°	24°	36°

Dimensions in mm subject to manufacturing tolerance

Brief Guide of Instructions: Replacing an old diaphragm

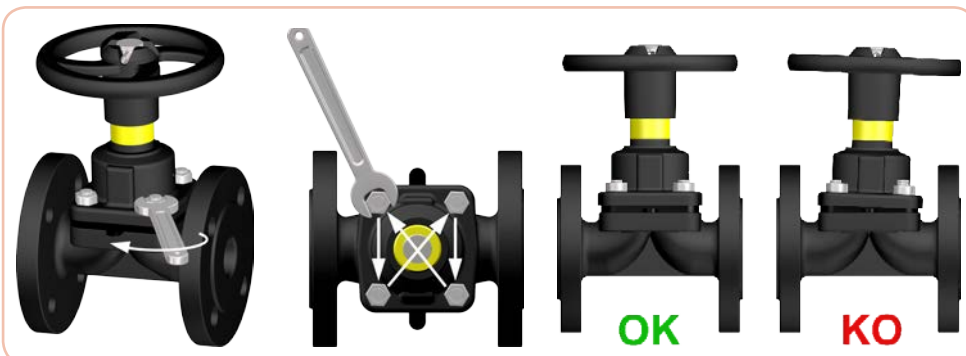
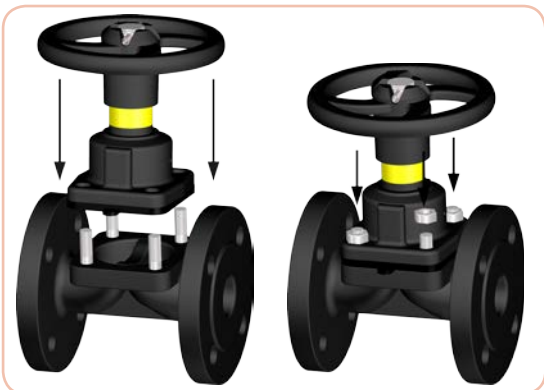
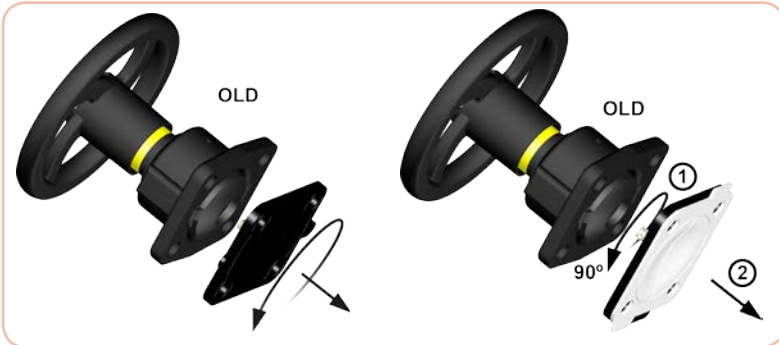
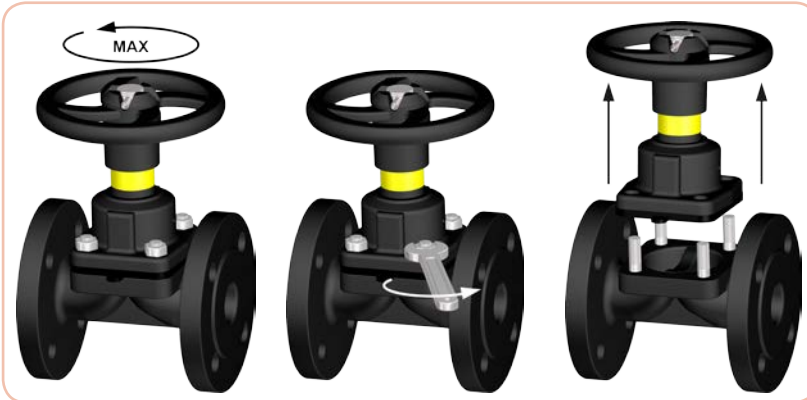

Weir Type Diaphragm Valves with Pneumatic Actuator

Main Features

- For DIAVAL manufactured valves in weir and straight through type, with rubber diaphragms and PTFE / rubber backed diaphragms.
- Rugged & compact design, long life span at the plant. Favourable size / performance ratio.
- Rolling diaphragm design, allowing long cycle operations.
- Single acting (Direct and reverse actions).
- High quality spring, large thrust.
- Visual position indicator for open / close.
- Burnished stem protected by bellow.
- Maintenance-free O-ring sealing with flexible guiding.
- Possibility of assembly of additional devices / accessories.
- Operating ambient temperatures -40°C to +100°C.
- Fully traceable at the manufacture facility, identified by aluminum riveted plates.
- Optional top mounted emergency hand wheels for manual operation.
- Compliant with Machinery Directive 2006/42/EC

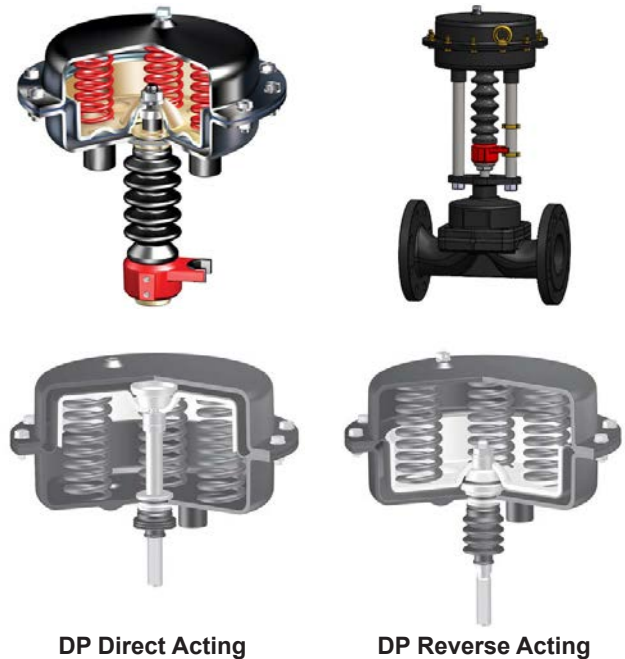

Working Principle

Direct Acting actuator is designed to operate from a normally open position. Air pressure on the top side of actuator diaphragm closes the valve and the spring opens the valve when the air is released from the actuator.

Reverse Acting actuator is designed to operate from a normally closed position. Air pressure on the bottom side of the actuator diaphragm opens the valve. When air is released spring closes the valve.

Control Accesories

There is a number of control accessories available to be assembled on to the ARI actuators. These accessories are comprehensive of limit switches (mechanical or inductive type), proximity sensors, solenoid valves, air speed regulators, positioners, air gauge sets... and many other customized solutions.

Control accessories may be specified and provided by the customer or by DIAVAL, however, only those accessories installed and tested at any DIAVAL facilities are covered by a performance guarantee.

Tests - After Market

All actuators are tested after assembly and before dispatch. Tests are comprehensive of visual and functional tests as per EN-12266-1/DIN 3230 P.3 - EN.10.204/2.2

Actuators can be serviced at DIAVAL facilities where a stock of common spares is permanently available. Off site service engineers are available on demand and against usual service rates.

Operating and Maintenance Instructions

Please ensure that the DIAVAL Operating and Maintenance Instructions are provided by your supplier along with the valves. Do not try to start maintenance without having read and understood the Essential Safety Guidelines. Please consult us for further information.

Standard Materials

Only the best quality materials are incorporated to the DIAVAL manufacturing process and are subject to a strict quality control by our DIAVAL engineers at the assembly plant.

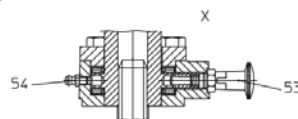
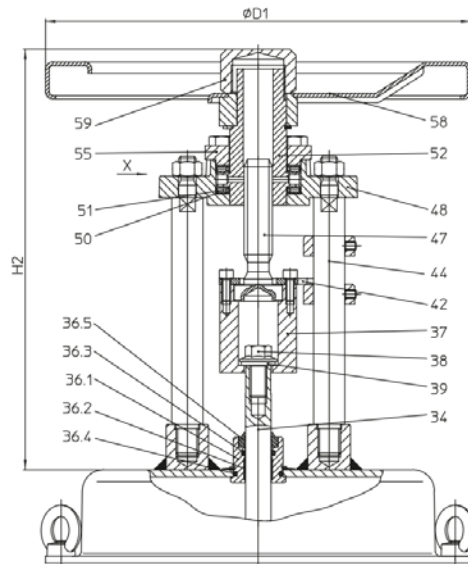
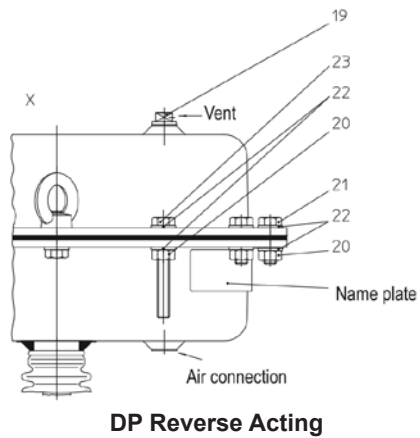
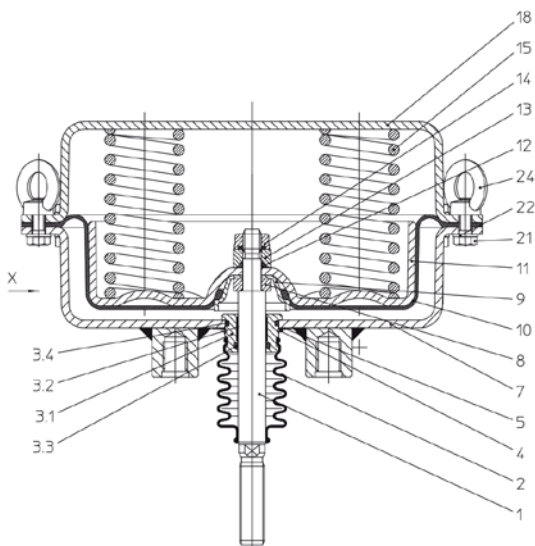
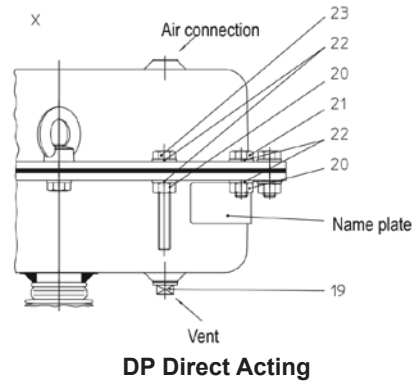
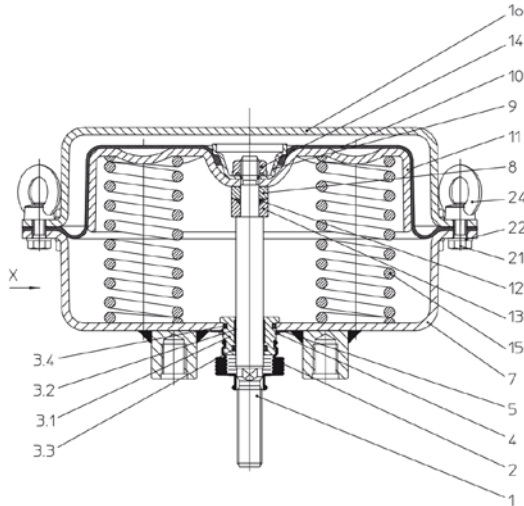

Top Handwheel (Optional)

Standard Materials

Pos.	Description	Material
1	Stem	X20Cr13+QT, 1.4021+QT
2	Bellow seal	EPDM50 or 42CR
3	Stem guiding *	X20Cr13+QT, 1.4021+QT
3.1	Stem guiding *	X20Cr13+QT, 1.4021+QT
3.2	Guiding band *	PTFE + 25%C
3.3	O-ring (stem) *	NBR
3.4	O-ring (guiding) *	NBR
3.5	Scraper *	NBR
4	Retaining ring	FSt - A3B
5	Spring plate	FSt (Fe/Zn12B)
6 / 7	Lower diaphragm casing (DP32-34Tri)	DD13+QT, 1.0335+QT (powder coated)
7	Lower diaphragm casing (DP35)	P265GH, 1.0425 / S235JR, 1.0037
8	Bushing	X20Cr13+QT, 1.4021+QT
9	Diaphragm lange	DD13+QT, 1.0335+QT (Fe/Zn12B) or X20Cr13+QT,
10	Rolling diaphragm *	1.4021+QT
11	Diaphragm plate (DP32-34Tri)	NBR + webbing
11	Diaphragm plate (DP35) *	DD13+QT, 1.0335+QT (Fe/Zn12B)
12	O-ring	St 52-3 G 03 g, 1.0570 G 03 g
13	Bushing	NBR
14	Flange nut	X20Cr13+QT, 1.4021+QT
15	Compression spring *	8 - A4G
16	Spring centring	FDSiCr
17	Spring centring	DC01, 1.0330 (Fe/Zn12B)
18	Upper diaphragm casing (DP32-34Tri)	St 52-3 G 03 g, 1.0570 G 03 g
18	Upper diaphragm casing (DP35)	DD13+QT, 1.0335+QT (powder coated)
19	Screwed cap	P265GH, 1.0425 / S235JR, 1.0037
20	Hexagon nut (DP32-34Tri) 1)	Polyäthylen
20	Hexagon nut (DP35) 1)	8 - A4G

Pos.	Description	Material
21	Hexagon screw (DP32-34Tri) 1)	C35E, 1.1181
21	Hexagon screw (DP35) 1)	8.8 - A4G
22	Washer	8.8 - A4G
23	Hexagon screw (DP32-34Tri) 1)	St - A4G
23	Hexagon screw (DP35) 1)	8.8 - A4G
24	Eye nut 1)	10.9 - A2G
34	Stem extension	8-A4G
36.1	Bellow seal *	X20Cr13+QT, 1.4021+QT
36.2	Guiding band *	X14CrMoS17+QT, 1.4104+QT
36.3	O-ring *	PTFE +25%C
36.4	O-ring *	NBR
36.5	Scraper *	NBR
37	Bushing	NBR
38	Hexagon screw	X20Cr13+QT, 1.4021+QT
39	Washer	8.8 - A4G
42	Torsion lock	X20Cr13+QT, 1.4021+QT
44 1	Distance column	8.8 - A4G
47	Stem	1SMn30+C, 1.0715+C (Fe/Zn12B)
48	Traverse	X20Cr13+QT, 1.4021+QT
50	Axial-washer	EN-JS1049, EN-GJS-400-18U-LT (Fe/Zn12B)
51	Axial-dial ring	St
52	Threaded bush	St
53	Catch pin	CuZn35Ni3Mn2Al-Pb-R490, CW710RR490
54	Lubricating nipple	St, Cu
55	Covering for traverse	5.8 - A4G
58	Handwheel	S235JR, 1.0037 (Fe/Zn12B)
59	Safety cap	Fe P01, 1.0330 (epoxy coating)

Weir Type Diaphragm Valves with Direct Acting Pneumatic Actuator- Rubber Diaphragm

Main Dimensions

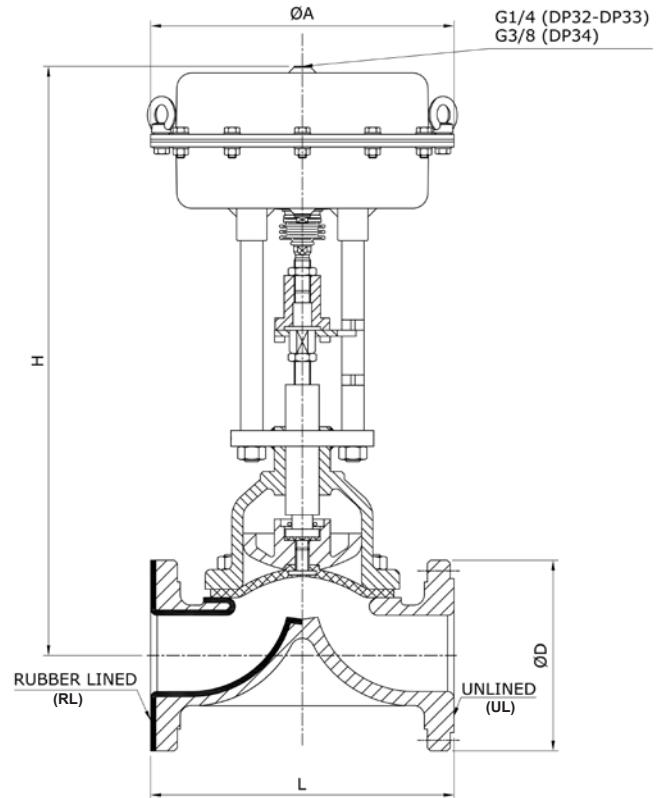
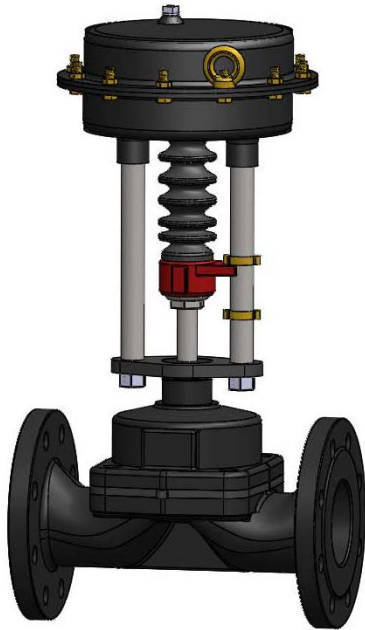

DN	L			H	ØD	ØA
	EN 558 S1 (DIN 3202 F1)		EN 558 S7 (BS 5156)			
	UL/RL	UL	RL			
15	130	108	114	415	95	250
20	150	117	123	427	105	250
25	160	127	133	434	115	250
32	180	146	152	444	140	250
40	200	159	165	476	150	250
50	230	190	196	471	165	250
65	290	216	222	503	185	250
80	310	254	260	520	200	250
100	350	305	313	736	220	405
125	400	356	364	786	250	405
150	480	406	414	856	285	405

Dimensions in mm subject to manufacturing tolerance.

Dimensions are based on the serialized manufacture and should be taken as preliminary.

Please, bear in mind the service clearance area when planning a skid or when installation happens in a very tight area.

Actuation Selection Chart

Direct Acting (actuator opens at air failure, springs to open/air to close).

Valve Size	Actuator Type	Max. Closing Pressure 100% ΔP (bar)	Max. Closing Pressure 0% ΔP (bar)	Air Supply to Close (bar)
DN15	DP32021020NA	10	10	1,5-2,0
DN20	DP32021020NA	10	10	1,5-2,0
DN25	DP32021020NA	10	10	2,0-2,5
DN32	DP32021020NA	10	10	2,0-2,5
DN40	DP32021020NA	10	10	2,0-2,5
DN50	DP32021020NA	10	10	2,0-2,5
DN65	DP32021020NA	8	8	3,0-3,5
DN80	DP32021030NA	8	8	3,5-4,0
DN100	DP34021050NA	8	8	2,5-3,5
DN125	DP34021050NA	8	8	3,5-4,5
DN150	DP34021065NA	6	6	4,0-5,0

Information / restriction of technical rules need to be observed!
Installation, Operating and Maintenance Manual can be downloaded at www.comeval.es

The engineer, designing a system or a plant, is responsible for the selection of the correct valve
Product suitability must be verified, contact manufacturer for information

Weir Type Diaphragm Valves with Reverse Acting Pneumatic Actuator- Rubber Diaphragm

Main Dimensions

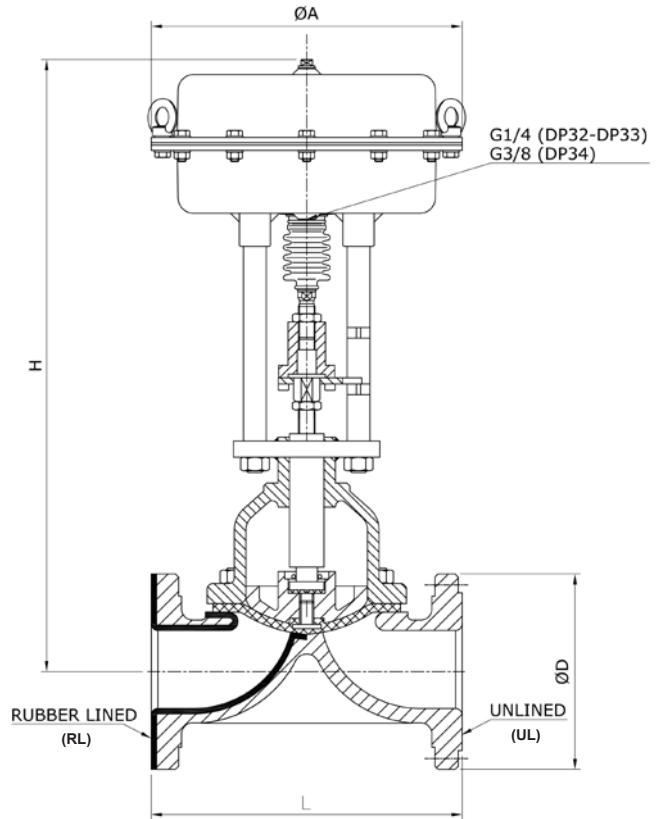
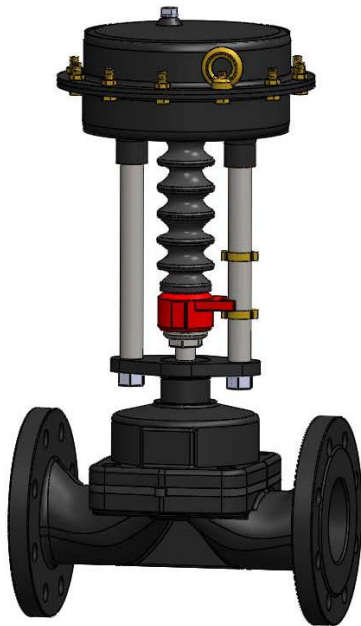

DN	L			H	ØD	ØA
	EN 558 S1 (DIN 3202 F1)		EN 558 S7 (BS 5156)			
	UL/RL	UL	RL			
15	130	108	114	415	95	250
20	150	117	123	427	105	250
25	160	127	133	434	115	250
32	180	146	152	444	140	250
40	200	159	165	476	150	250
50	230	190	196	471	165	250
65	290	216	222	503	185	250
80	310	254	260	520	200	250
100	350	305	313	736	220	405
125	400	356	364	786	250	405
150	480	406	414	856	285	405

Dimensions in mm subject to manufacturing tolerance.

Dimensions are based on the serialized manufacture and should be taken as preliminary.

Please, bear in mind the service clearance area when planning a skid or when installation happens in a very tight area.

Actuation Selection Chart

Reverse Acting (actuator closes at air failure, air to open/spring to close).

Valve Size	Actuator Type	Max. Closing Pressure 100% ΔP (bar)	Max. Closing Pressure 0% ΔP (bar)	Air Supply to Open (bar)
DN15	DP32041220NC	10	9	2,0-2,5
DN20	DP32041220NC	10	9	2,0-2,5
DN25	DP32082420NC	10	9	3,0-3,5
DN32	DP32082420NC	10	9	3,0-3,5
DN40	DP32082420NC	9	7	3,0-3,5
DN50	DP32082420NC	8	6	3,0-3,5
DN65	DP32152520NC	8	6	3,0-3,5
DN80	DP33153030NC	8	6	4,0-4,5
DN100	DP34153050NC	8	6	4,0-4,5
DN125	DP34204050NC	7	4	5,0-5,5
DN150	DP34204065NC	6	3	5,0-5,5

Information / restriction of technical rules need to be observed!
Installation, Operating and Maintenance Manual can be downloaded at www.comeval.es

The engineer, designing a system or a plant, is responsible for the selection of the correct valve
Product suitability must be verified, contact manufacturer for information

Weir Type Diaphragm Valves with Direct Acting Pneumatic Actuator- PTFE Diaphragm

Main Dimensions

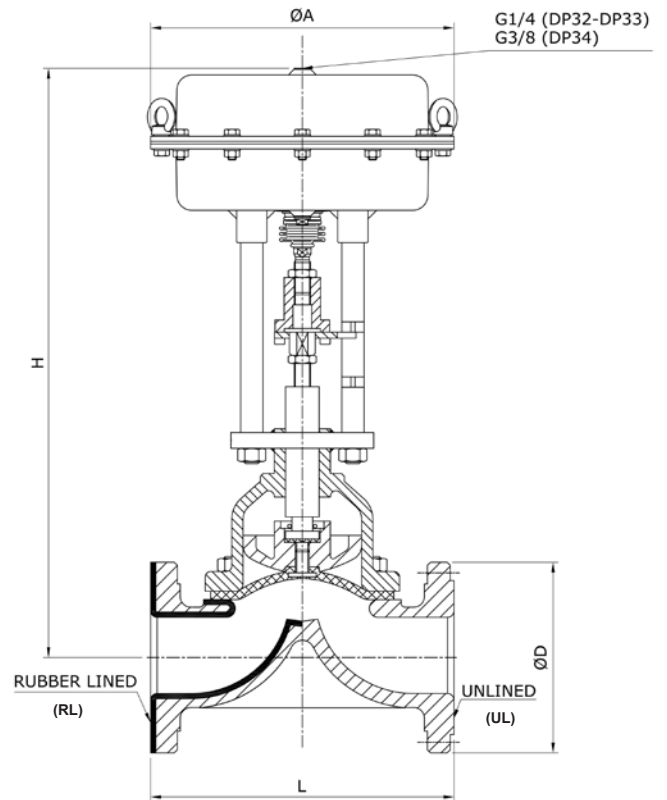
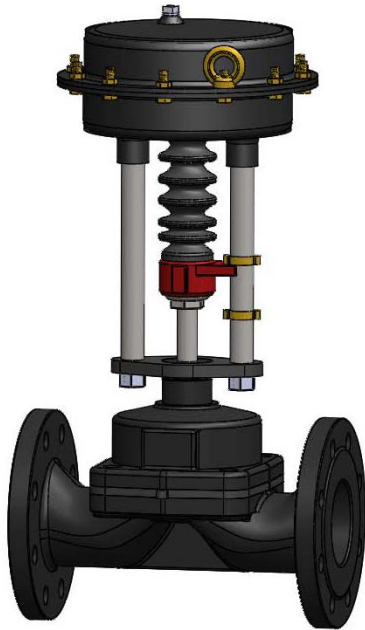

DN	L			H	ØD	ØA
	EN 558 S1 (DIN 3202 F1)		EN 558 S7 (BS 5156)			
	UL/RL	UL	RL			
15	130	108	114	415	95	250
20	150	117	123	427	105	250
25	160	127	133	434	115	250
32	180	146	152	444	140	250
40	200	159	165	476	150	250
50	230	190	196	471	165	250
65	290	216	222	503	185	250
80	310	254	260	520	200	250
100	350	305	313	736	220	405
125	400	356	364	786	250	405
150	480	406	414	856	285	405

Dimensions in mm subject to manufacturing tolerance.

Dimensions are based on the serialized manufacture and should be taken as preliminary.

Please, bear in mind the service clearance area when planning a skid or when installation happens in a very tight area.

Actuation Selection Chart

Direct Acting (actuator opens at air failure, springs to open/air to close).

Valve Size	Actuator Type	Max. Closing Pressure 100% ΔP (bar)	Max. Closing Pressure 0% ΔP (bar)	Air Supply to Close (bar)
DN15	DP32021020NA	6	6	2,0-2,5
DN20	DP32021020NA	6	6	2,0-2,5
DN25	DP32021020NA	6	6	2,5-3,0
DN32	DP32021020NA	6	6	2,5-3,0
DN40	DP32021020NA	6	6	3,0-3,5
DN50	DP32021020NA	6	6	3,5-4,0
DN65	DP32021020NA	6	5	4,5-5,0
DN80	DP32021030NA	6	4	5,0-5,5
DN100	DP34021050NA	6	4	4,5-5,0
DN125	DP34021065NA	6	4	4,5-5,0
DN150	DP34021065NA	5	3	5,0-5,5

Information / restriction of technical rules need to be observed!
Installation, Operating and Maintenance Manual can be downloaded at www.comeval.es

The engineer, designing a system or a plant, is responsible for the selection of the correct valve
Product suitability must be verified, contact manufacturer for information

Weir Type Diaphragm Valves with Reverse Acting Pneumatic Actuator- PTFE Diaphragm

Main Dimensions

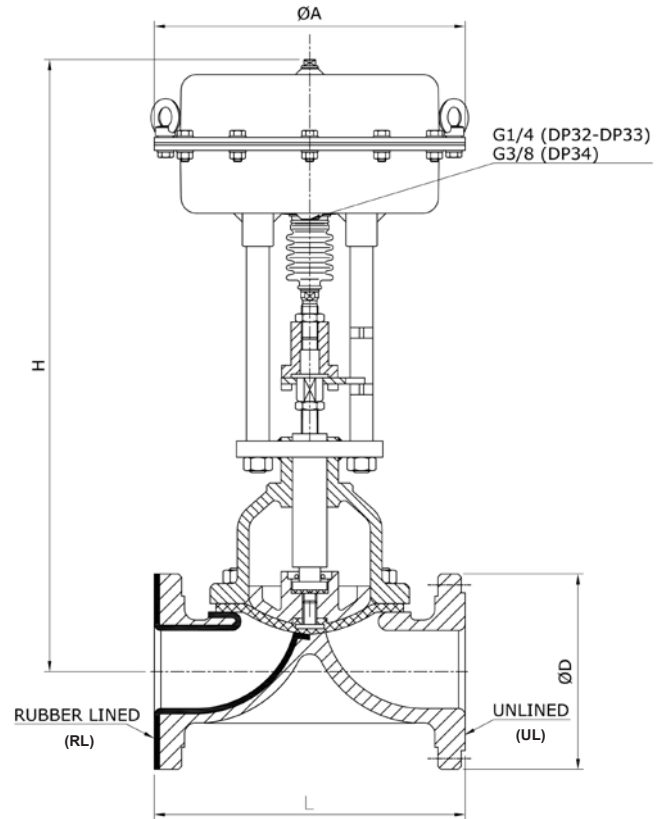
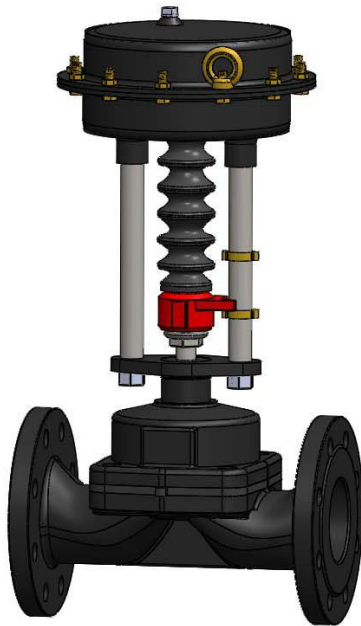

DN	L			H	ØD	ØA
	EN 558 S1 (DIN 3202 F1)		EN 558 S7 (BS 5156)			
	UL/RL	UL	RL			
15	130	108	114	415	95	250
20	150	117	123	427	105	250
25	160	127	133	434	115	250
32	180	146	152	444	140	250
40	200	159	165	476	150	250
50	230	190	196	471	165	250
65	290	216	222	503	185	250
80	310	254	260	520	200	250
100	350	305	313	736	220	405
125	400	356	364	786	250	405
150	480	406	414	856	285	405

Dimensions in mm subject to manufacturing tolerance.

Dimensions are based on the serialized manufacture and should be taken as preliminary.

Please, bear in mind the service clearance area when planning a skid or when installation happens in a very tight area.

Actuation Selection Chart

Reverse Acting (actuator closes at air failure, air to open/spring to close).

Valve Size	Actuator Type	Max. Closing Pressure 100% ΔP (bar)	Max. Closing Pressure 0% ΔP (bar)	Air Supply to Open (bar)
DN15	DP32041220NC	6	6	2,0-2,5
DN20	DP32041220NC	6	6	2,0-2,5
DN25	DP32082420NC	6	6	3,0-3,5
DN32	DP32082420NC	6	6	3,0-3,5
DN40	DP32082420NC	6	4	3,0-3,5
DN50	DP32082420NC	6	4	3,5-4,0
DN65	DP32152520NC	6	4	4,0-4,5
DN80	DP33153030NC	6	4	4,5-5,0
DN100	DP34153050NC	6	4	5,0-5,5
DN125	DP34204050NC	6	4	5,0-5,5
DN150	DP34204065NC	5	3	5,0-5,5

Information / restriction of technical rules need to be observed!
Installation, Operating and Maintenance Manual can be downloaded at www.comeval.es

The engineer, designing a system or a plant, is responsible for the selection of the correct valve
Product suitability must be verified, contact manufacturer for information

Piston Pneumatic Actuator
Main Dimensions

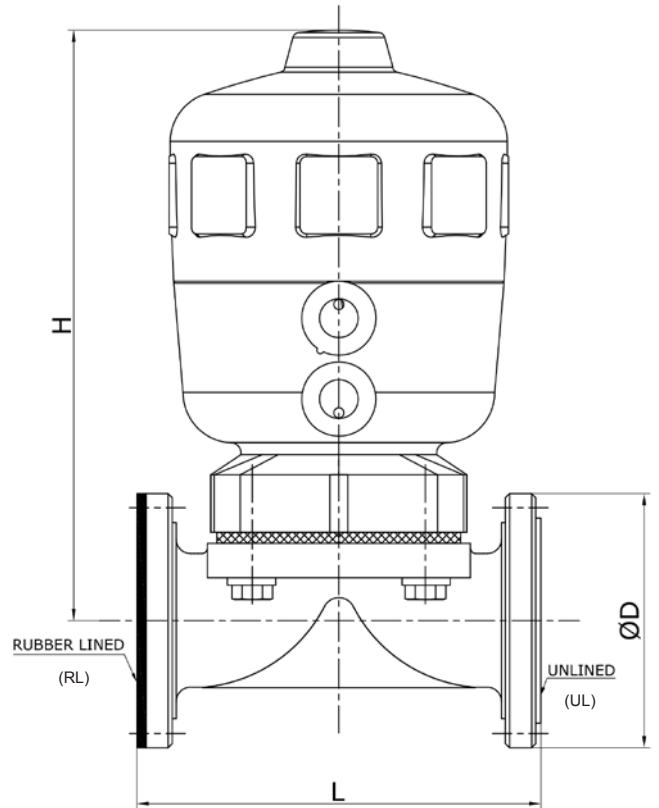

Actuator shell material:
PA Polyamide
Temperature: -10°C to 60°C*

*For higher temperature also available PPS Polyphenylene sulfide version

DN	L			H	ØD
	EN 558 S1 (DIN 3202 F1)	EN 558 S7 (BS 5156)			
	UL/RL	UL	RL		
15	130	108	114	155	95
20	150	117	123	175	105
25	160	127	133	250	115
32	180	146	152	250	140
40	200	159	165	250	150
50	230	190	196	250	165
65	290	216	222	265	185

Dimensions in mm subject to manufacturing tolerance.

Dimensions are based on the serialized manufacture and should be taken as preliminary.

Please, bear in mind the service clearance area when planning a skid or when installation happens in a very tight area.

Accessories
Manual Override

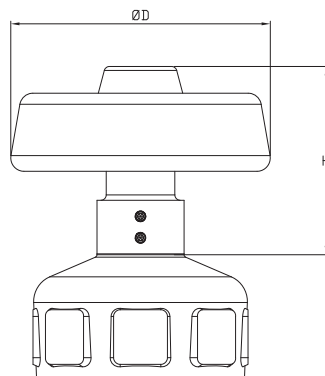

VALVE SIZE	ØD	H
DN 15-25	80	68
DN 32-65	150	82

Other accessories: position indicator, positioner, proximity switches, stroke limitation, NAMUR-adapter for solenoid valves.

Electrical feedback signaller

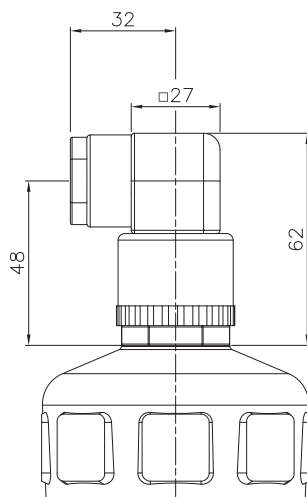

VALVE SIZE	CODE
DN15-40	B701515000000
DN40-65	B701516000000

Max. stroke limitation

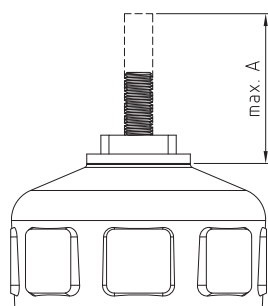

VALVE SIZE	CODE	max. A
DN15-25	B6378660000000	40
DN32	B6378670000000	55
DN40-65	B6378680000000	55

Min./max. stroke limitation

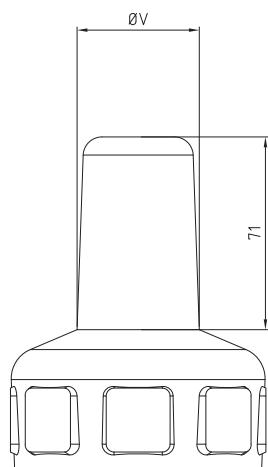

VALVE SIZE	CODE	ØV
DN15-25	B6368200000000	39
DN32	B6368210000000	53
DN40-65	B6407030000000	53

Electrical position feedback

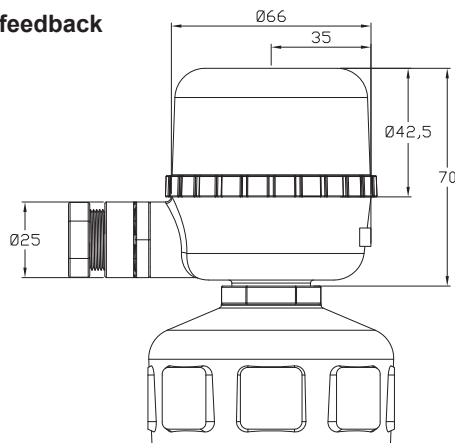

VALVE SIZE	CODE
DN15-25	B682264000000
DN32-65	B682265000000

External magnetic inductive position feedback

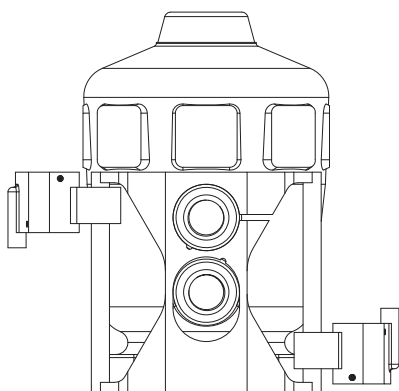

VALVE SIZE	CODE
DN15	B2FCINME3MP050
DN20	B2FCINME3MP063
DN25	B2FCINME3MP080
DN32	B2FCINME3MP100
DN40	B2FCINME3MP100
DN50	B2FCINME3MP100
DN65	B2FCINME3MP125

Namur-adapter for pilot valves

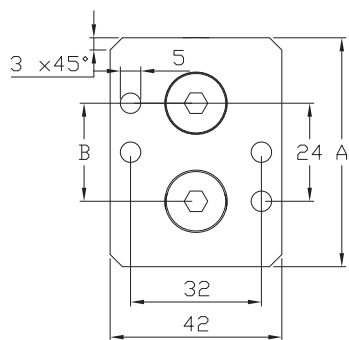

VALVE SIZE	CODE	A	B
DN20-32	B6371130000000	46	24
DN40-65	B6371140000000	58	30



Actuation Selection Chart - Single Acting - Rubber Diaphragm

Reverse Acting (actuator closes at air failure, air to open/spring to close).

Valve Size	Actuator Type	Max. Closing Pressure 100% ΔP (bar)	Max. Closing Pressure 0% ΔP (bar)	Air Supply to Open (bar)
DN15	BNC142492N0015	8	7	5
DN20	BNC142494Q0020	10	8	5.5
DN25	BNC142497K0025	10	8.5	5.5
DN32	BNC142499V0032	10	9	5.5
DN40	BNC142500A0040 BNC14350200040*	6	5	5.5
DN50	BNC142502Y0050 BNC14368800050*	4	3.5	5.5
DN65	BNC142730F0065 BNC14836100065*	7	4.5	5.5

*For valves with laminated PTFE diaphragm

Direct Acting (actuator opens at air failure, spring to open/air to close).

Valve Size	Actuator Type	Max. Closing Pressure (bar)	Air Supply to Close (bar)
DN15	BNA16926800015	10	4,5
DN20	BNA14377100020	10	4,5
DN25	BNA14377400025	10	5,5
DN32	BNA14377500032	10	5
DN40	BNA14377600040	10	6,5
DN50	BNA14377800050	5,5 8	6 8
DN65	BNA16502400065	8 10	6 7

Actuation Selection Chart - Double Acting - Rubber Diaphragm

Valve Size	Actuator Type	Max. Closing Pressure (bar)	Air Supply to Close (bar)
DN15	BDE14143500015	10	3,5
DN20	BDE14143700020	10	2,5
DN25	BDE14143900025	10	2,5
DN40	BDE14659200040	10	4,5
DN50	BDE14144600050	6 8	6 8
DN65	BDE16185400065	8 10	6 7

Information / restriction of technical rules need to be observed!
Installation, Operating and Maintenance Manual can be downloaded at www.comeval.es

The engineer, designing a system or a plant, is responsible for the selection of the correct valve
Product suitability must be verified, contact manufacturer for information

Material Selection

Information contained in the Material Selection Chart is a combination of theoretical and application data, and should be taken as a guide only. Pressure-temperature rating, material compatibility and other parameters also to be considered for rubber selection. Please consult our Technical Department for a particular application. With constant material / process changes, Diaval® cannot accept responsibility for diaphragm and/or body material performance resulting from such changes.

Fluid	Body Material		Diaphragm		Recommendations
Abrasive slurry - non acidic	Soft rubber lined	Ductile iron	D10		
Abrasive slurry - acidic	Butyl lined		D20 or D30		
Acetic acid up to 50%	Halar® lined	FEP lined	D20 or D30		
Acetic acid over 50%	Halar® lined	FEP lined	D20 or D30		
Acetic acid (glacial)	Halar® lined	FEP lined	D20 or D30		Sealed bonnet
Acetoacetic ester	Halar® lined	Stainless steel	D90		
Acetone	Ductile iron		D20 or D30		
Acetylene	Ductile iron	Cast steel	D20 or D30		No copper
Alum	Hard rubber lined	Soft rubber lined	D10	D20 or D30	
Alumina	Ductile iron	Soft rubber lined	D20 or D30	D10	
Aluminium sulphate	Hard rubber lined	Butyl rubber lined	D10	D20 or D30	
Ammonia, aqueous	Ductile iron	Stainless steel	D10	D20 or D30	Sealed bonnet
Ammonia gaseous	Ductile iron	Stainless steel	D10	D20 or D30	Sealed bonnet
Ammonium nitrate	Butyl rubber lined	FEP lined	D20 or D30	D50	
Ammonium phosphate	Butyl rubber lined		D10	D20 or D30	
Ammonium sulphate	Butyl rubber lined		D20 or D30		
Aniline	FEP lined	Stainless steel	D92		
Antifreeze	Ductile iron	Butyl rubber lined	D20 or D30		
Apple juice	Stainless steel		D15		
Asbestos cement	Soft rubber lined	Ductile iron	D10		
Ash handling	Soft rubber lined	Ductile iron	D10		
Asphalt	Ductile iron	Cast steel	D20 or D30		
Avcat	Stainless steel	Cast steel	D70	D20 or D30	
Avgas	Stainless steel	Cast steel	D70		
Avtag	Stainless steel	Cast steel	D70	D20 or D30	
Avtur	Stainless steel	Cast steel	D70	Butyl	
Barium carbonate	Hard rubber lined	Stainless steel	D20 or D30	D50	
Barium sulphate	Soft rubber lined	Hard rubber lined	D20 or D30		
Barytes	Soft rubber lined	Hard rubber lined	D10		
Basic slag	Soft rubber lined	Ductile iron	D10		
Battery acid	Hard rubber lined	Butyl rubber lined	D20 or D30		
Bauxite	Soft rubber lined		D10		
Beet juice	Ductile iron	Hard rubber lined	D20 or D30		
Benzene	Butyl rubber lined	Halar® lined	D92		
Benzyl alcohol	FEP lined	Halar® lined	D92		Sealed bonnet
Bilge (ships)	Ductile iron	Cast steel	D40		
Blast furnace gas	Ductile iron	Ductile iron	D20 or D30		
Bleaching powder	Hard rubber lined	Hypalon lined	D60		
Borax	Hard rubber lined		D10		
Brine	Hard rubber lined	Stainless steel	D10	D92	
Brine, chlorinated	Hard rubber lined	Hypalon lined	D60		
Bromine	FEP lined		D92		Sealed bonnet
Bcf	Ductile iron		D92		
Butane	Ductile iron	Cast steel	D40	D50	Sealed bonnet
Butanol	Ductile iron	Cast steel	D20 or D30		
Calcium carbonate	Ductile iron	Soft rubber lined	D10	D20 or D30	
Calcium chloride	Hard rubber lined		D10	D20 or D30	
Calcium hydroxide	Ductile iron	Soft rubber lined	D10	D20 or D30	

Material Selection

Fluid	Body Material		Diaphragm		Recomendations
Calcium hypochlorie	Hard rubber lined	Ductile iron	D60	D10	
Calcium phosphate	Butyl rubber lined	Hard rubber lined	D10	D20 or D30	
Calcium sulphate	Soft rubber lined	Ductile iron	D10	D20 or D30	
Calor gas	Ductile iron		D40		
Cane juice	Ductile iron	Soft rubber lined	D20 or D30		
Carbon black	Soft rubber lined	Ductile iron	D10		
Carbon dioxide	Ductile iron	Fductile iron	D20 or D30		
Carbon monoxide	Ductile iron		D20 or D30		Sealed bonnet
Carbon tetrachloride	Ductile iron	Ductile iron	D92		
Castor oil	Ductile iron		D20 or D30		
Caustic potash	Ductile iron	Butyl rubber lined	D10	D20 or D30	Sealed bonnet
Caustic soda	Ductile iron	Butyl rubber lined	D10	D20 or D30	Sealed bonnet
Cement (dry and slurry)	Soft rubber lined	Ductile iron	D10		
Chalk	Ductile iron	Soft rubber lined	D10		
China clay	Ductile iron	Soft rubber lined	D10		
Chlorinated brine	FEP lined	Hard rubber lined	D60	D10	
Chlorine gas dry	Ductile iron	Halar® lined	D97		
Chlorine gas moist	FEP lined	Halar® lined	D97		
Chlorine gas wet	FEP lined	Halar® lined	D97		
Chlorine water	Hard rubber lined	Halar® lined	D10		
Chloroform	FEP lined	Stainless steel	D92		
Chrome alum	Butyl rubber lined	Halar® lined	D20 or D30		
Chrome plating solns	Butyl rubber lined	Halar® lined	D20 or D30		
Chrome tanning solns	Butyl rubber lined	Halar® lined	D20 or D30	D92	
Clays and slips	Soft rubber lined	Ductile iron	D10		
Coal dust	Soft rubber lined	Ductile iron	D10		
Coal gas	Ductile iron	Ductile iron	D20 or D30	D40	
Coal slurry	Soft rubber lined	Ductile iron	D10		
Coke oven gas	Ductile iron	Ductile iron	D20 or D30	D40	
Compressed air (oil free)	Ductile iron	Cast steel	D40	D20 or D30	
Compressed air (oily)	Ductile iron	Cast steel	D40	D70	
Concrete	Soft rubber lined	Ductile iron	D10		
Copper plating solutions	Butyl rubber lined	Halar® lined	D20 or D30		
Copper sulphate	Butyl rubber lined	Halar® lined	D20 or D30		
Creosote	Hard rubber lined	Halar® lined	D70		
Creosote	Ductile iron	Halar® lined	D70		
Crude oil	Cast steel	Ductile iron	D70	D92	
Cutting oil	Hard rubber lined		D40		
Demineralised water	Hard rubber lined	Stainless steel	D20 or D30	D92	
Detergents	Hard rubber lined	Halar® lined	D20 or D30	D10	
Dibutyl phthalate	Halar® lined	Ductile iron	D92		
Dichlorodiluoromethane	Ductile iron	Cast steel	D92		
Diesel oil	Ductile iron	Cast steel	D70		
Diethyl ether	Stainless steel	Ductile iron	D92		Sealed bonnet
Diethylene glycol	Ductile iron	Stainless steel	D20 or D30		
Disinfectant (general)	Ductile iron	Halar® lined	D50		
Dye liquors	FEP lined	Butyl rubber lined	EPDM	D20 or D30	
Electrolytic tinplating solutions	Butyl rubber lined	FEP lined	D20 or D30		
Ethane	Ductile iron	Cast steel	D40	D50	
Ethanol	Ductile iron	Stainless steel	D20 or D30	D20 or D30	
Ether	Ductile iron	Stainless steel	D92		Sealed bonnet
Ethyl acetate	Stainless steel	Halar® lined	D20 or D30		
Ethyl alcohol	Ductile iron	Stainless steel	D20 or D30		
Ethylene	Ductile iron	Stainless stee	D20 or D30		

Material Selection

Fluid	Body Material		Diaphragm		Recomendations
Ethylene glycol	Ductile iron	Stainless steel	D20 or D30		
Ferric sulphate	Butyl rubber lined	Halar® lined	D10		
Fertilizers (dry powders)	Soft rubber lined	Ductile iron	D10		
Fertilizer slurries (wet process)	Butyl rubber lined	Ductile iron	D20 or D30	D20 or D30	
Fire foam	Ductile iron	Cast steel	D40		
Flue gas	Ductile iron	Cast steel	D40	D20 or D30	
Fly ash	Ductile iron	Soft rubber lined	D10	Butyl	
Freon	Ductile iron	Ductile iron	D92	D50	
Fuel oil	Ductile iron	Cast steel	D40		
Gas (coal)	Ductile iron	Cast steel	D40		
Gas (natural)	Ductile iron	Cast steel	D40		
Gasoline	Cast steel	Ductile iron	D70		
Glucose	Stainless steel	Stainless steel	D20 or D30		
Glycerine	Stainless steel	Hard rubber lined	D20 or D30		
Gravel	Soft rubber lined	Ductile iron	D10		
Grease	Ductile iron	Cast steel	D40		
Gypsum	Soft rubber lined	Ductile iron	D10		
Hydraulic oils (vegetable based)	Ductile iron	Ductile iron	D20 or D30		
Hydraulic oils (mineral based)	Ductile iron	Ductile iron	D40		
Hydrobromic acid	FEP lined	Halar® lined	D92		
Hydrochloric acid	Hard rubber lined	Halar® lined	D10	D92	
Hydrofluoric acid	Butyl rubber lined	Halar® lined	D20 or D30		
Hydrogen	Ductile iron	Cast steel	D20 or D30	D10	Sealed bonnet
Hydrogen peroxide	Hard rubber lined	Stainless steel	PTFE/D70	D20 or D30	
Hypo	Hard rubber lined	Halar® lined	D10	D60	
Inert gases	Ductile iron	Ductile iron	D20 or D30		
Inks	Stainless steel	Halar® lined	D92	D20 or D30	
Insecticide solutions	Ductile iron	Ductile iron	D40	D20 or D30	
Instrument air	Ductile iron	Stainless steel	D20 or D30	D40	
Iron oxide slurry	Soft rubber lined	Ductile iron	D20 or D30		
Isopropanol	Ductile iron	Hard rubber lined	D10	D20 or D30	
Kaolin	Soft rubber lined	Ductile iron	D10		
Kerosene	Ductile iron	Stainless steel	D70	D92	
Laundry bleach	Hard rubber lined	Halar® lined	D60	D10	
Lime	Ductile iron	Soft rubber line	D10		
Liquid parafin	Ductile iron	Ductile iron	D40	D70	
Liquid petroleum gases (I.P.G.)	Ductile iron	Cast steel	D40	D20 or D30	Sealed bonnet
Lubricating oils	Hard rubber lined	Cast steel	D40	D70	
Magnesium chloride	Ductile iron	Butyl rubber lined	D10	D20 or D30	
Magnesium oxide	Butyl rubber lined	Hard rubber line	D10	D20 or D30	
Magnesium sulphate	Soft rubber lined	Ductile iron	D10	D20 or D30	
Magnetite	Hard rubber lined	Ductile iron	D10		
Methane	Ductile iron	Ductile iron	D20 or D30	D40	
Methanol	Ductile iron	Stainless steel	D20 or D30		
Methanol/water mixture	Ductile iron	Hard rubber lined	D20 or D30	D10	
Methylated spirits	Ductile iron	Stainless steel	D20 or D30		
Methyl ethyl ketone (mek)	Stainless steel	FEP lined	D92		
Methyl isobutyl ketone	Stainless steel	FEP lined	D92	D20 or D30	
Milk	Stainless steel		D15		
Mineral oil	Ductile iron	Cast steel	D70	D40	
Molasses	Ductile iron	Stainless steel	D20 or D30		
Monosodium glutamate	Hard rubber lined	Stainless steel	D10		

Material Selection

Fluid	Body Material		Diaphragm		Recomendations
Mortar and cement	Soft rubber lined	Ductile iron	D10	D20 or D30	
Naphtha	Ductile iron	Cast steel	D70		
Napthalene	Ductile iron	Cast steel	D70		
Natural gas	Ductile iron	Stainless steel	D40	D50	
Nickel plating solutions	Butyl rubber lined	Halar® lined	D20 or D30	D60	
Nickel plating sludge	Butyl rubber lined	Halar® lined	D20 or D30	D60	
Nitric acid	FEP lined	Stainless steel	D92	D70	Check grade of S.S.
Nitric acid / hydrofluoric acid mix	FEP lined	Halar® lined	D92		
Nitrogen	Ductile iron	Stainless steel	D20 or D30		
Nitrous oxide (dry)	Stainless steel	FEP lined	D20 or D30		
Oils, animal	Ductile iron	Stainless steel	D40	D92	
Oils, cutting	Ductile iron	Stainless steel	D70	D40	
Oil fuel	Ductile iron	Stainless steel	D70	D40	
Oils, lubricating	Ductile iron	Stainless steel	D70	D40	
Oils, mineral	Ductile iron	Cast steel	D70	D40	
Oil, rolling	Ductile iron	Cast steel	D70	D40	
Oil, transformer	Ductile iron	Stainless steel	D70	D40	
Oils, vegetable	Stainless steel	Ductile iron	D40	D70	
Oleum	FEP lined	Halar® lined	D92		
Olive oil	Stainless steel	Ductile iron	D40	D92	
Oxygen	Ductile iron	Stainless steel	D50	D20 or D30	Degreased for oxygen
Paint (oil based)	Ductile iron	Stainless steel	D40	D20 or D30	
Paint (water based)	Ductile iron	Stainless steel	D20 or D30	D92	
Paper pulp	Hard rubber lined	Butyl rubber lined	D10	D20 or D30	
Paper stock	Hard rubber lined	Butyl rubber lined	D10	D20 or D30	
Parafin	Ductile iron	Stainless steel	D70	D40	
Parafin wax	Ductile iron	Cast steel	D40	D70	
Paraquet	Ductile iron	Halar® lined	D40		Sealed bonnet
Pentane	Ductile iron	Cast steel	D70	D92	
Perchloroethylene	Ductile iron	Cast steel	D70	D92	
Petrol	Ductile iron	Cast steel	D70		Sealed bonnet
Petroleum jelly	Ductile iron	Halar® lined	D70	D40	
Phosphoric acid	Butyl rubber lined	Halar® lined	D20 or D30		
Photographic developers	Halar® lined	FEP lined	D20 or D30	D92	
Plating solutions	Butyl rubber lined	Halar® lined	D20 or D30		
Polyethylene glycol	Ductile iron	Stainless steel	D10	D20 or D30	
Potassium chloride	Hard rubber lined	Halar® lined	D10	D20 or D30	
Potassium cyanide	Hard rubber lined	Halar® lined	D10	D20 or D30	Sealed bonnet
Potassium ferricyanide	Hard rubber lined	Halar® lined	D20 or D30	D10	
Potassium hydroxide	Ductile iron	Hard rubber lined	D20 or D30	D10	Sealed bonnet
Potassium hypochlorite	Hard rubber lined	Halar® lined	D60	D10	
Potassium phosphate	Hard rubber lined	Butyl rubber lined	D20 or D30	D10	
Pottery slip	Soft rubber lined	Ductile iron	D10		
Producer gas	Ductile iron	Cast steel	D20 or D30	D40	
Propane (gas or liquid)	Ductile iron	Cast steel	D40	D50	
Radioactive effluents	Butyl rubber lined	Stainless steel	D20 or D30		No copper parts.
Rock salt	Soft rubber lined	Hard rubber lined	D10	D20 or D30	
Rolling oil	Ductile iron	Cast steel	D70	D10	
Salt	Soft rubber lined	Hard rubber lined	D10	D20 or D30	
Sand	Soft rubber lined	Ductile iron	D10	D20 or D30	
Sea water	Stainless steel	Hard rubber lined	D10	D20 or D30	
Sewage	Ductile iron	Hard rubber lined	D10	D50	
Silver plating solutions	Butyl rubber lined	Halar® lined	D20 or D30		

Material Selection

Fluid	Body Material		Diaphragm		Recomendations
Slaked lime	Ductile iron	Soft rubber lined	D10	D20 or D30	
Slip (pottery)	Soft rubber lined	Ductile iron	D10		
Soap lye	Ductile iron	Butyl rubber lined	D10	D20 or D30	
Soap solutions	Ductile iron	Butyl rubber lined	D10	D20 or D30	
Sodium bicarbonate	Ductile iron	Halar® lined	D20 or D30	D92	
Sodium chloride	Soft rubber lined	Hard rubber lined	D10	D20 or D30	
Sodium hydroxide	Ductile iron	Hard rubber lined	D20 or D30	D10	Sealed bonnet
Sodium hydroxide (oily)	Ductile iron	Stainless steel	D50	D40	
Sodium hypochlorite	Hard rubber lined	Halar® lined	D10	D70	
Solvent naphtha	Ductile iron	Cast steel	D70	D40	
Stannic chloride	Halar® lined	FEP lined	D20 or D30	D92	
Starch solutions	Ductile iron	Halar® lined	D20 or D30	D60	
Stearic acid	Stainless steel	Halar® lined	D92		
Sugar	Ductile iron	Stainless steel	D20 or D30	D15	
Sulphur dioxide	Butyl rubber lined	Hard rubber lined	D20 or D30		
Sulphuric acid below 75%	Butyl rubber lined	Halar® lined	D20 or D30	D70	
Sulphuric acid 75-95%	Halar® lined	FEP lined	D92	D70	
Sulphuric acid 95-99%	Ductile iron	Halar® lined	D92	D70	Sealed bonnet
Sulphuric acid over 99%	FEP lined	Halar® lined	D92		
Syrups (sugar)	Ductile iron	Stainless steel	D20 or D30	D15	
Tetrachloroethane	Ductile iron	Stainless steel	D92	D70	Sealed bonnet
Textile dyes	Halar® lined	Butyl rubber lined	D20 or D30	D92	
Tin plating solutions	Halar® lined	Butyl rubber lined	D92	D20 or D30	
Titanium dioxide	Butyl rubber lined	Hard rubber lined	D20 or D30	D10	
Toluene	Ductile iron	Cast steel	D92		
Transformer oil	Stainless steel	Ductile iron	D70		
Trichloroethylene	Ductile iron	Stainless steel	D92	D70	Sealed bonnet
Turpentine	Ductile iron	FEP lined	D40	D70	Sealed bonnet
Vegetable oils	Ductile iron	Stainless steel	D70	D92	
Vinegar	Stainless steel		D92		
Water cold	Ductile iron	Stainless steel	D10	D20 or D30	
Water de-mineralised	Hard rubber lined	FEP lined	D10	D92	
Water drinking	Stainless steel	Stainless steel	D20 or D30		
Water oily	Ductile iron	Gunmetal	D40	D50	
Water (salt and brackish)	Stainless steel	Hard rubber lined	D10	D20 or D30	
Wood pulp	Ductile iron	Soft rubber lined	D10	D20 or D30	
Wort	Ductile iron	Stainless steel	D20 or D30		
Xylene	Ductile iron	Cast steel	D92	D70	
Zinc chloride	Soft rubber lined	Stainless steel	D10	D20 or D30	
Zinc oxide	Stainless steel	Butyl rubber lined	D20 or D30	D92	
Zinc plating solutions	Butyl rubber lined	Hard rubber lined	D20 or D30		

New Horizons in the
Process Industry.

Diaval®



www.diaval.com