

DOUBLE BLOCK & BLEED DUAL EXPANDING PLUG VALVES



arflu
INDUSTRIAL VALVES



PETROCHEMICAL
DIVISION

DOUBLE BLOCK & BLEED DUAL EXPANDING PLUG VALVES



arflu
INDUSTRIAL VALVES



PETROCHEMICAL
DIVISION



We are pleased to present you our company which, since its foundation more than 25 years ago, is dedicated to the production of high quality valves. Since 1988 we have been manufacturing all kind of valves mainly for petrochemical, energy, gas, marine services and water and we are proud to manufacture our valves under our brand ARFLU.

ARFLU 's quality guarantee system as well as all its processes and procedures, both technical ones regarding products and in the organization of the company are certified according to the UNE-EN ISO 9001 standard. In addition ARFLU is certified according to H module of 97/23/CE of the EU. Though this certification is extremely important for our company, it must be said that the best certification and guaranty we can offer is the fact that our customers are placing their confidence in ARFLU products day by day. Living in a world of technology and communications as it is today, in ARFLU we try to keep at the forefront of industry. ARFLU owns the latest and most powerful informatic technology systems in order to have our whole organization perfectly communicated and to be in constant contact with customers worldwide. ARFLU is one of the most qualified companies in its field. We develop tailor made solutions as well as we provide customized advice and training for our clients.



arflu

INNOVATION, QUALITY, DESIGN

QUALITY:



This point is the cornerstone of our company philosophy and a key to our global competitiveness.

The complete Arflu team is trained in quality processes to ensure that customers, no matter where they are located, receive consistent and excellent quality in our products and services.

Our valves are characterized by their high quality, guaranteed through testing one by one, each with an individual number for complete traceability.

Our test benches and laboratory facilities are provided with equipment to realize examinations of all kinds like hydrostatic and pneumatic pressure test, thickness verification, fugitive emission test and all types of non-destructive examinations.

THE QUALITY POLICY

ARFLU, S.A. Management has implemented and maintains a system of quality management based on the requirements of the UNE-EN-ISO 9001 (2008) : "Quality management system Requirements" for manufacturing activities of valves for fluid control.

The Quality management system's aim is to achieve Arflu's customer satisfaction by complying with all requirements, specified by both the client and legal or regulatory requirements as well as the necessary ones to assure the effectiveness of the manufacture.

Therefore ARFLU , S.A management promises to fulfil the following general targets:

- Managing quality of services provided, according to International Standard ISO 9001 (2008).
- Compliance with the requirements agreed with our customers (product specifications, delivery, agreed price, etc.), strengthening their confidence in our organization.
- Compliance with other requirements: legal requirements and implicit requirements to ensure adequacy of services provided to customer needs
- Continuous improvement of the efficiency of quality management.

The Quality Policy is spread to the whole personnel through training seminars and by distribution of controlled copies of the present document. In addition, another controlled copy is placed in the bulletin board of ARFLU, S.A. By this means, ARFLU, S.A ensures that the Quality Policy is understood by the whole personnel of the company.

The review of the Quality Policy, as well as the establishment and review of specific and quantified quality targets, is carried out by the management during system review.



DOUBLE BLOCK AND BLEED SERVICE

GENERAL CONSIDERATIONS:

Double Block & Bleed service is a challenge in many applications, as drop-tight sealing on both the upstream and the downstream side is essential in many sectors like:

- Tank Storage
- Loading/unloading Stations
- Multi-Product Manifolds
- Metering Stations
- Aviation fuel Services
- Custody Transfer Units
- Offshore Platforms

Common valve designs like most gate and ball valves depend on line pressure or springs to achieve sealing and cannot guarantee long-term double block & bleed service as their sealing mechanism is based on friction and tearing and consequently seal abrasion and scored seating elements may lead to product loss and contamination.



The antiquated system to achieve double block & bleed features is the use of 2 block valves and a spool piece with bleed valve. This configuration requires a lot of space and the operation of 2 valves, which especially in the actuated version is a very expensive and maintenance-intensive solution.



ARFLU dual expanding plug valves represent the “single valve solution” and avoid all these problems, they are easy to operate, require very little maintenance and offer verifiable double block & bleed service with an extraordinary long lifetime.

Not only do we help our clients to avoid product loss, our valves prevent fuel contamination in Multi- Product-Manifolds, avoid errors in meter calibration and at the same time help to protect health and the environment by positively containing the fluid in the pipeline.



FEATURES OF ARFLU DUAL EXPANDING PLUG VALVES:

NO FRICTION

Our dual expanding plug valves are based on a rising stem design with cam and pin and a rotating plug with retracting slips that assure low operating torques and friction-free opening and closing. The plug is double guided to assure that both slips seal equally on both sides.

DOUBLE BLOCK & BLEED

ARFLU dual expanding plug valves have a double block and bleed function both upstream and downstream which otherwise would require two separated valves to obtain the same effect. This does not only mean an easier operation but also lower cost of maintenance and saving space.

MAINTENANCE AND SERVICEABILITY

ARFLU dual expanding plug valves are top and bottom entry type. If changing the slips is required, these can easily be accessed by removing the lower cover without any special tools. The valve should be in open position to remove the slips downwards.

BACK SEATING

Thanks to the back seat incorporated in our valves, stem packing can be adjusted and replaced easily, even if the line is under pressure.

STEM PACKING

ARFLU dual expanding plug valves are equipped with a full-size stem packing; special requirements like TA-Luft or other regulations regarding fugitive emissions, including live loaded packing, can easily be fulfilled.

LOWER TRUNNION

The lower trunnion is not part of the plug but incorporated in the lower cover, thus eliminating a body cavity where accumulation of particles may interfere with the valve function.

ACTUATION

ARFLU dual expanding plug valves can be equipped with any type of actuator, including linear pneumatic ones.

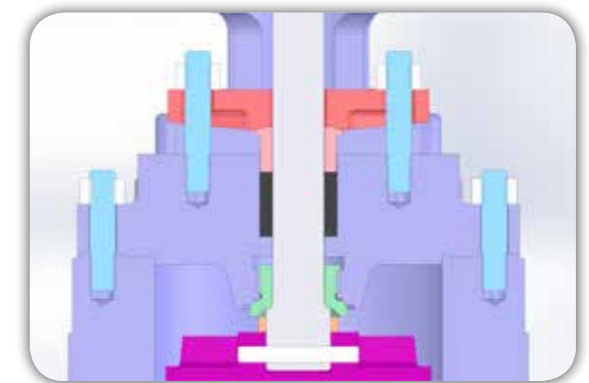
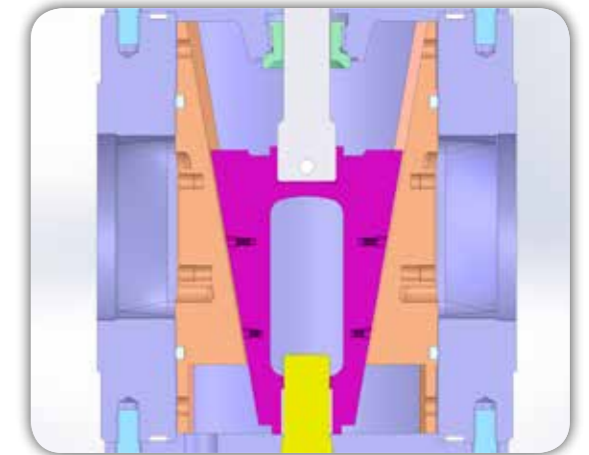

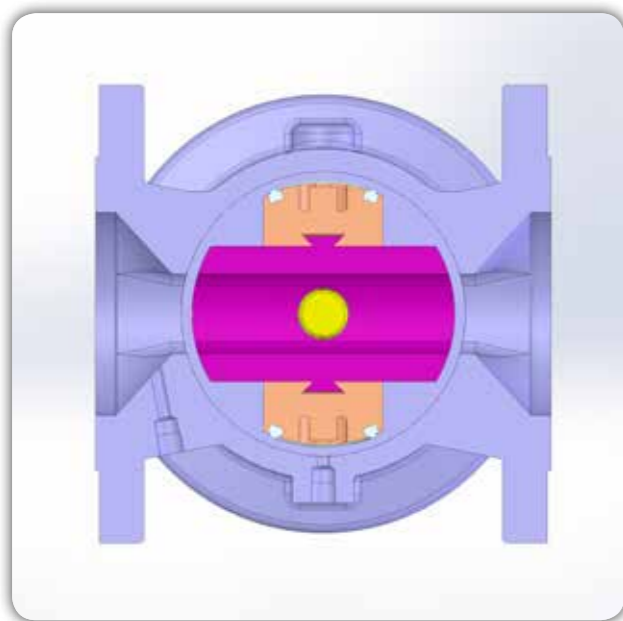

HOW IT WORKS

In the open position the slips with the permanently bonded seals are completely out of the flow and not in contact with the body.

When closing, the cam starts turning the plug 90 degrees and pushing it downwards to set the slips in front of the ports. During this process neither the slip nor the elastomer seat will be in contact with the body, therefore avoiding any friction force that would damage the sealing surface.

Finally the plug will continue to move downwards pushing and expanding the slips towards the ports until metal to metal closure is made, also obtaining a bubble tight closure due to the elastomer compression.

Opening the valve will take it through the same movements in reverse order, separating the slips from the body first, once again avoiding any damage to the parts, and afterwards turning 90 degrees until the flow path is totally opened.

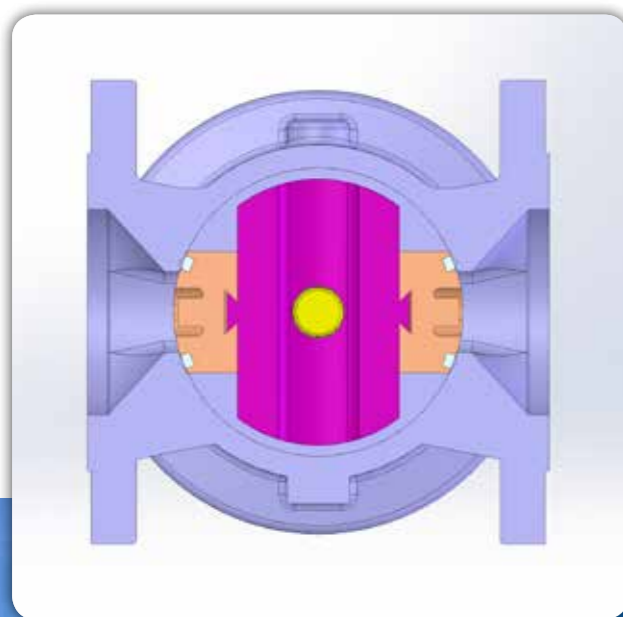

PRESSURE RELIEF DEVICES DUAL EXPANDING PLUG VALVES

A pressure relief device should be included in all Double Block & Bleed Plug valves in order to satisfy API 6D requirements. Even the slightest change in the temperature could result in a significant increase in body cavity pressure due to thermal expansion. For instance something as common as direct sunlight could increase the temperature, therefore all DEP valves in liquid service must include a pressure relief device.



1. MBV: MANUAL BODY BLEED.

This system is hand operated. In order to check the seal effectiveness the Double Block & Bleed Plug valve must be fully closed, then you can proceed to open the manual valve and bleed the body. Manual valve must be closed before reopening the DBB valve.



2. TRB: THERMAL RELIEF TO BODY.

This system routes excess pressure that might be generated due to thermal expansion. Once the thermal relief valve detects 25 psi above pipeline pressure the excess is released. This system includes an isolation valve that if closed will not let the overpressure be released, and therefore should be left open.



3. MBTR: MANUAL BLEED AND THERMAL RELIEF.

This system is a combination of a MBV and a TRB. The body can be manually bled and if 25 psi above pipeline pressure is detected, overpressure will be released. It also includes an isolation valve.



Other bleed systems like automatic body bleed or remote leak detection device are available upon request.

MATERIALS

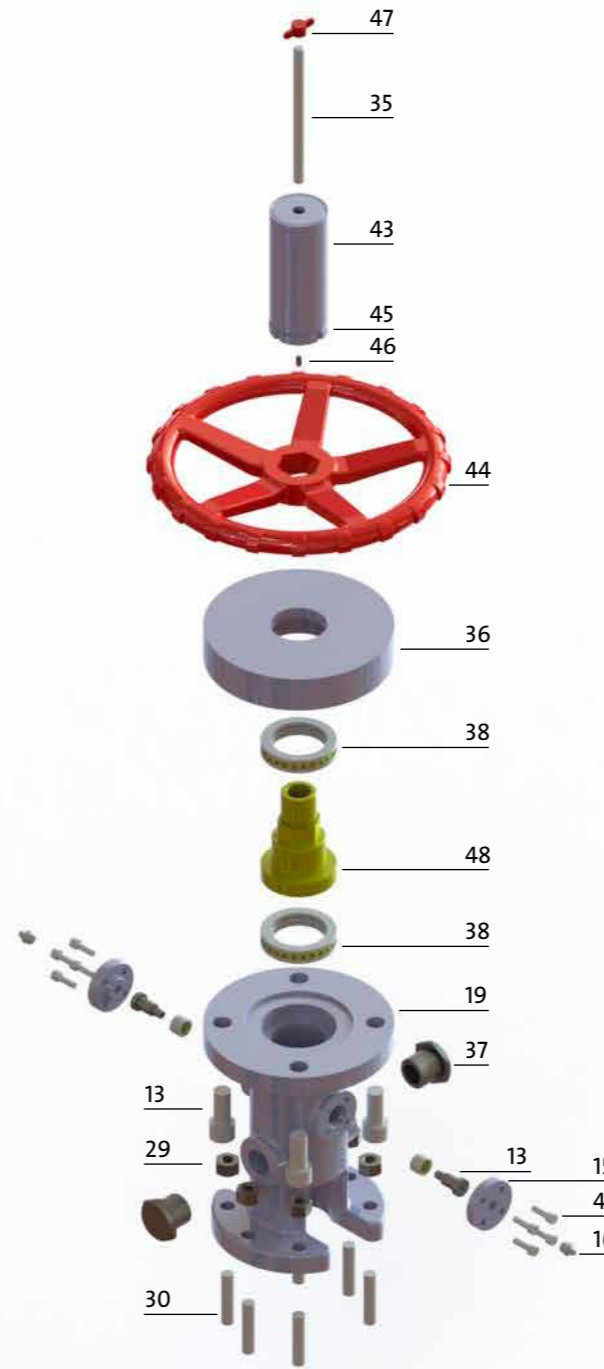
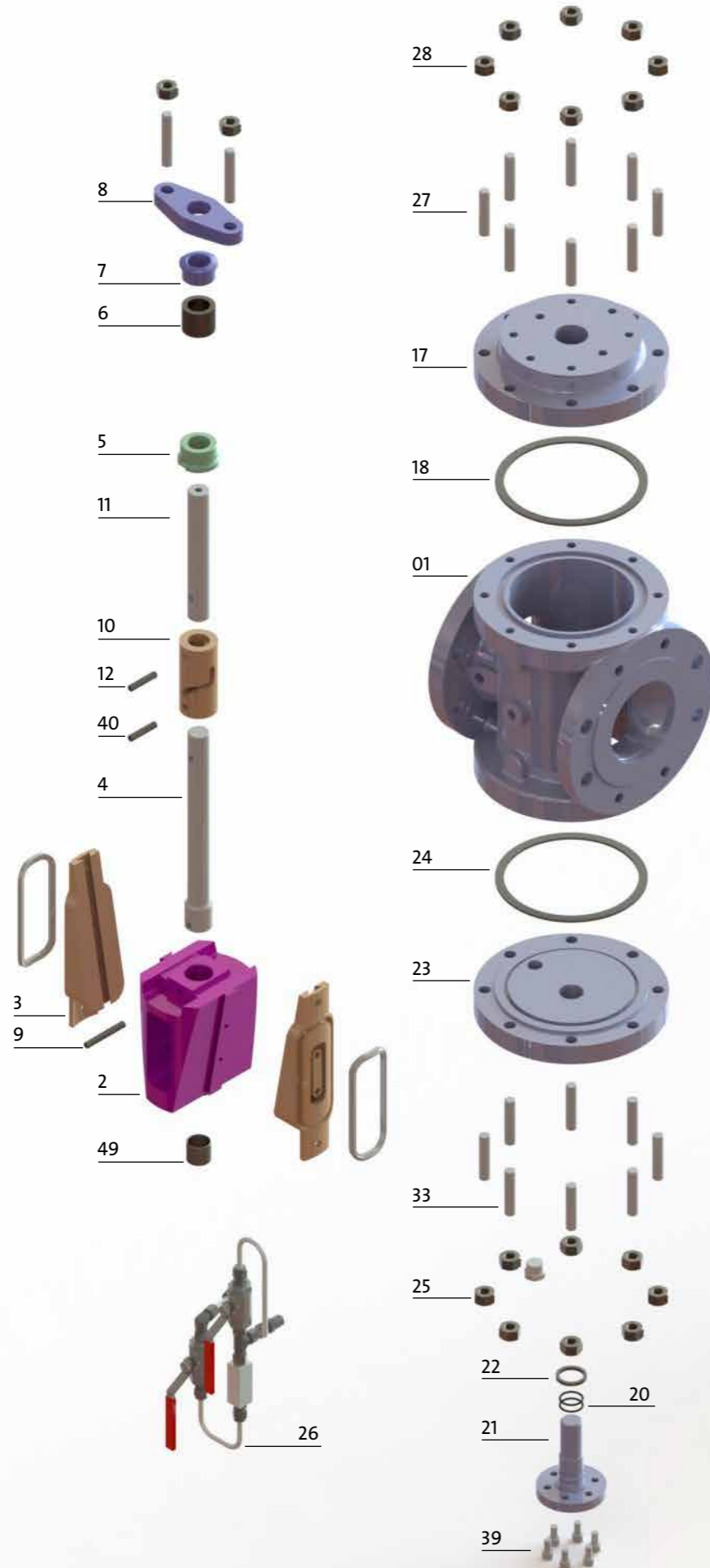

DUAL EXPANDING PLUG VALVE

ITEM	QUANT.	DENOMINATION	MATERIAL/STANDARD
01	1	BODY	ASTM A216 WCB + CR
02	1	PLUG	ASTM A216 WCB + ENP
03	2	SLIP	ASTM A536-80-55-06 + VITON
04	1	LOWER STEM	ASTM A182 F6A
05	1	BACKSEAT	ASTM A182 F6A
06	5	PACKING	GRAPHITE
07	1	GLAND RING	ASTM A182 F6A
08	1	GLAND FLANGE	ASTM A105
09	1	LOWER STEM PIN	17 -4PH
10	1	CAM	F158 C
11	1	UPPER STEM	ASTM A182 F6A
12	1	UPPER STEM/CAM PIN	17 -4PH
13	2	CAM PIN	17 -4PH
14	2	BEARING	ASTM CARBON STEEL
15	2	COVER	ASTM A216 WCB
16	2	GREASING INJECTOR	STEEL
17	1	UPPER COVER	ASTM A216 WCB
18	1	UPPER GASKET	SW316+GRAPHITE
19	1	YOKE	ASTM A216 WCB
20	2	O-RING	VITON
21	1	TRUNNION	ASTM A182 F6A
22	1	GASKET	GRAPHITE
23	1	LOWER COVER	ASTM A216 WCB
24	1	LOWER GASKET	SW316+GRAPHITE
25	1	DRAIN PLUG	ASTM A105N
26	1	BLEED SYSTEM	CARBON STEEL
27	8	COVER STUD	ASTM A193 B7
28	8	COVER NUT	ASTM A194 2H
29	6	YOKE NUT	ASTM A194 2H
30	6	YOKE STUD	ASTM A193 B7
31	2	STUD GLAND FLANGE	ASTM A193 B7
32	2	NUT GLAND FLANGE	ASTM A194 2H
33	8	LOWER COVER STUD	ASTM A193 B7
34	8	LOWER COVER NUT	ASTM A194 2H
35	1	POSITION INDICATOR STEM	POLYETHYLENE COATED
36	1	YOKE COVER	ASTM A105
37	2	PIN PLUG	17 -4PH
38	2	BEARING	CARBON STEEL
39	6	SCREW	8.8
40	1	LOWER STEM/CAM PIN	17 -4PH
41	8	SCREW	8.8
42	4	SCREW	8.8
43	1	INDICATOR COVER	STEEL
44	1	WHEEL	CARBON STEEL
45	1	WHEEL FIXING	CARBON STEEL
46	1	STUD	CARBON STEEL
47	1	POSITION INDICATOR	CARBON STEEL
48	1	STEM NUT	BRONZE
49	1	BUSHING	CARBON STEEL + PTFE

Other materials available upon request

MANUFACTURING PROGRAM

REDUCED BORE TYPE

Reduced Bore Valves are the standard execution with a 70% plug port.

CLASS 150 2" TO 48"
CLASS 300 2" TO 36"
CLASS 600 2" TO 30"

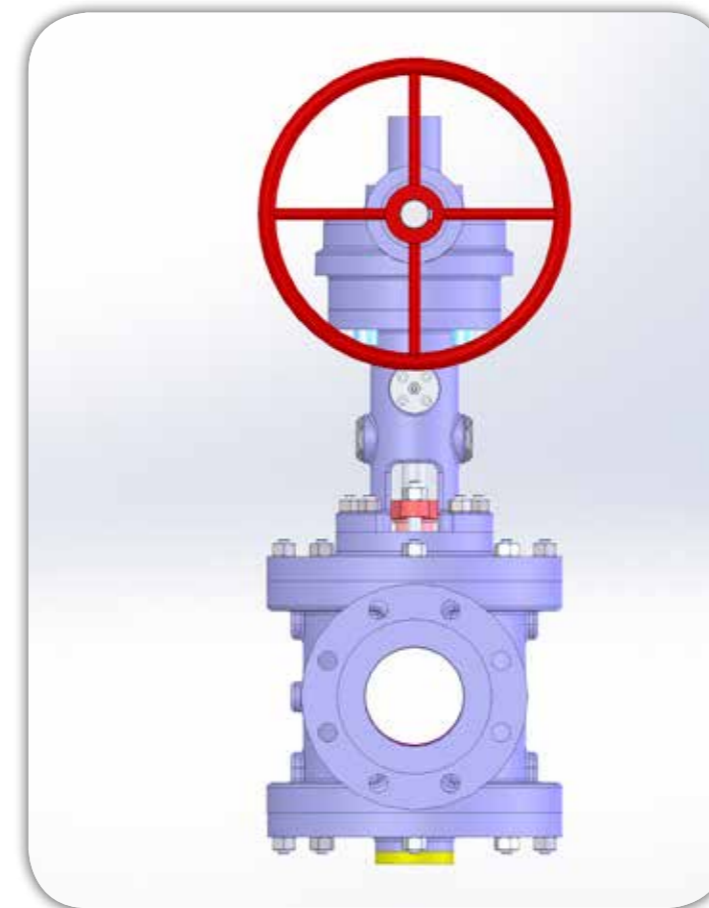
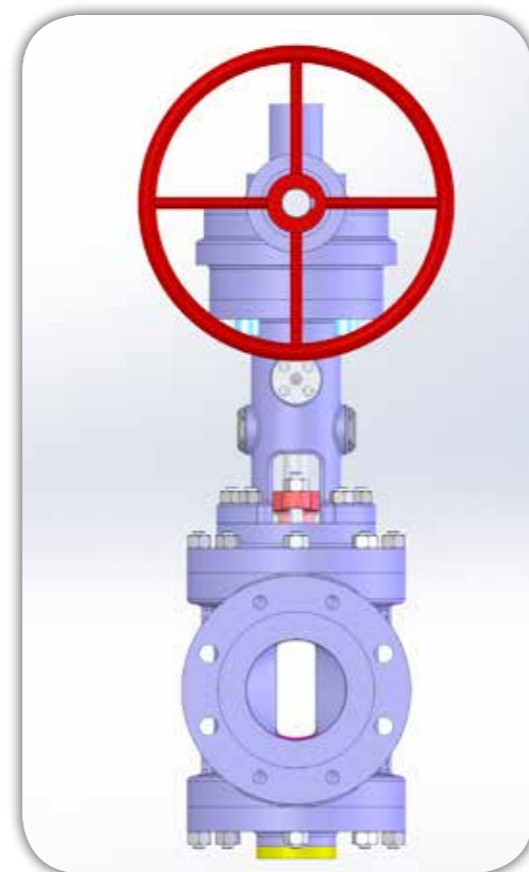
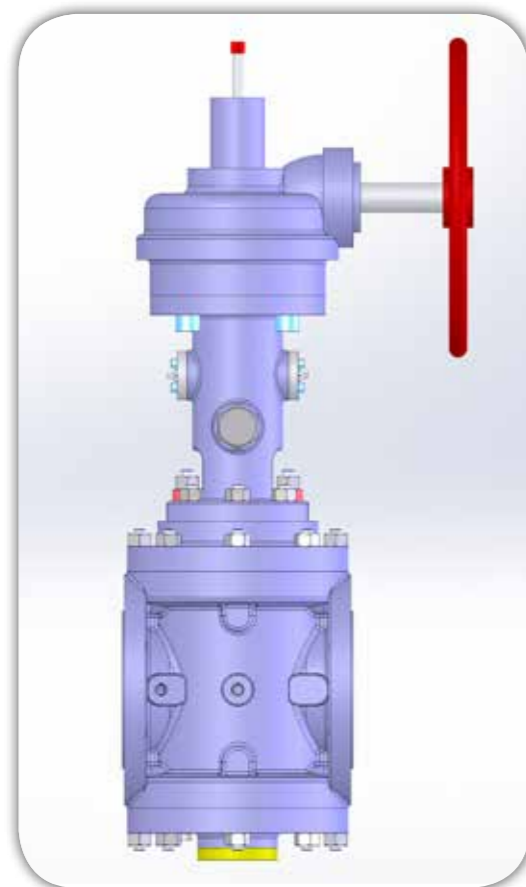

FULL BORE TYPE

Full bore valves have a minimum port area as per API 6D and are therefore suitable for the passage of pipeline scrapers.

CLASS 150 2" TO 36"
CLASS 300 2" TO 30"
CLASS 600 2" TO 16"

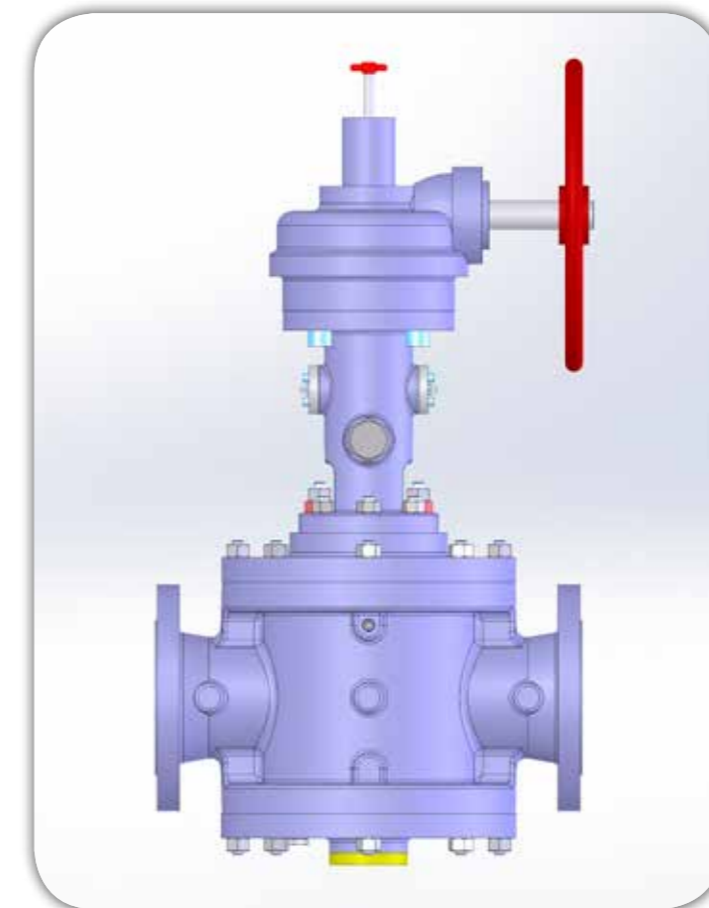

Dual Expanding Plug Valves for higher pressures or according to other standards are available upon request. This also includes venturi pattern type valves with ultra-short face to face dimensions.

technical datas

Dual Expanding Plug Valve

COD.
APDB-1000

DEPV REDUCED BORE CLASS 150 2" TO 48"

PETROCHEMICAL
& ENERGY DIVISION

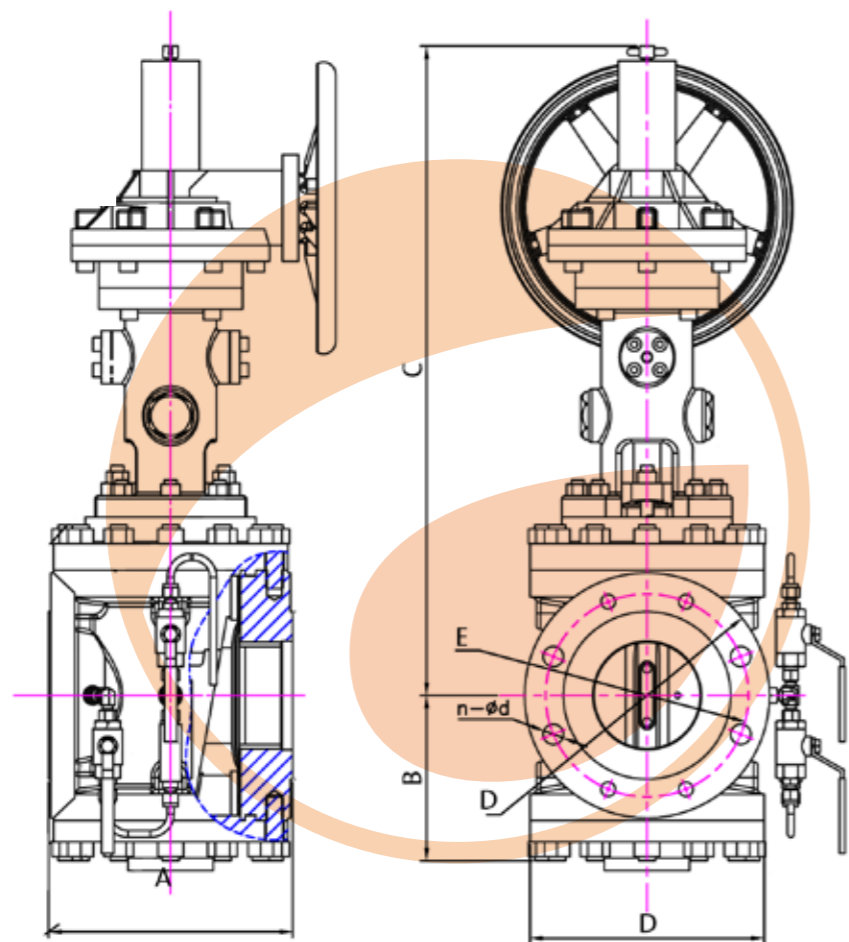

CLASS 150 REDUCED BORE

SIZE	A	B	C	D	E	OPERATOR
(inch)	(mm)	(mm)	(mm)	(mm)	(mm)	
2"	178	125	270	150	150	HANDWHEEL
3"	203	140	280	195	190	HANDWHEEL
4"	229	150	315	225	230	HANDWHEEL
6"	266	215	400	270	280	HANDWHEEL
8"	292	265	460	310	345	GEARBOX
10"	330	315	500	340	405	GEARBOX
12"	355	340	725	415	485	GEARBOX
14"	381	390	830	530	535	GEARBOX
16"	406	500	975	600	595	GEARBOX
20"	864	650	1120	690	700	GEARBOX
24"	914	750	1250	800	815	GEARBOX
30"	1295	900	1375	970	*	GEARBOX
36"	1727	1050	1500	1140	*	GEARBOX

NOTE - Dimensions are for information only. Certified dimensional drawings are available upon request.

*NOTE - Larger sizes upon request.

Dual Expanding Plug Valve

COD.
APDB-1000

DEPV FULL BORE CLASS 150 2" TO 36"

PETROCHEMICAL
& ENERGY DIVISION

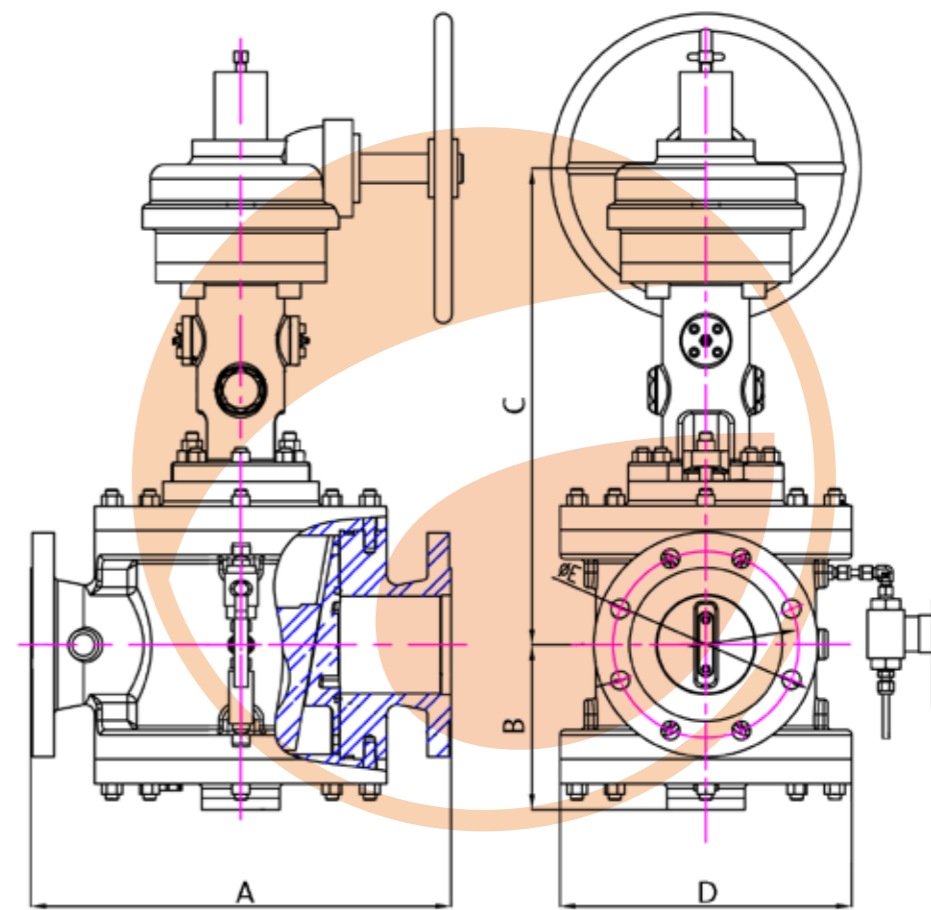

CLASS 150 FULL BORE

SIZE	A	B	C	D	E	OPERATOR
(inch)	(mm)	(mm)	(mm)	(mm)	(mm)	
2"	298	125	270	240	150	HANDWHEEL
3"	343	140	280	255	190	HANDWHEEL
4"	432	150	315	300	230	HANDWHEEL
6"	533	215	400	330	280	GEARBOX
8"	610	265	460	370	345	GEARBOX
10"	787	315	500	400	405	GEARBOX
12"	914	340	725	415	485	GEARBOX
14"	978	390	830	440	535	GEARBOX
16"	991	500	975	545	595	GEARBOX
20"	1245	650	1120	650	700	GEARBOX
24"	1346	750	1250	770	815	GEARBOX
30"	1727	900	1375	1040	*	GEARBOX
36"	2108	1050	1500	1310	*	GEARBOX

NOTE - Dimensions are for information only. Certified dimensional drawings are available upon request.

technical datas

Dual Expanding Plug Valve

COD.
APDB-3000

DEPV REDUCED BORE CLASS 300 2" TO 36"

PETROCHEMICAL
& ENERGY DIVISION

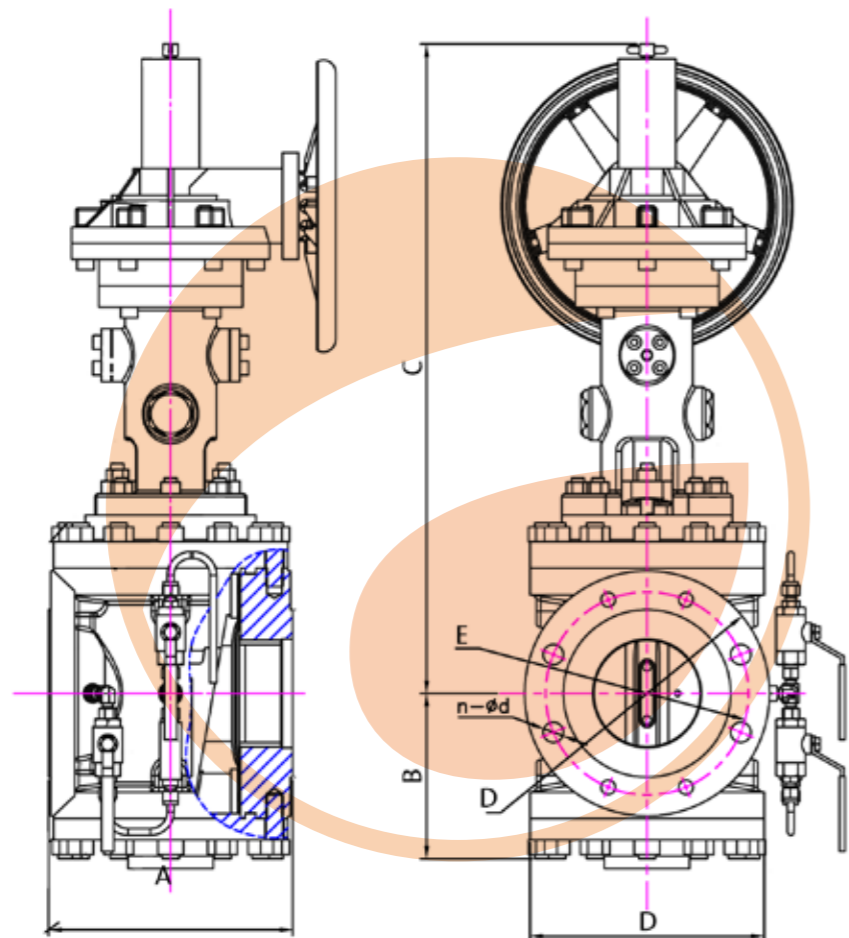

CLASS 300 REDUCED BORE

SIZE	A	B	C	D	E	OPERATOR
(inch)	(mm)	(mm)	(mm)	(mm)	(mm)	(mm)
2"	216	135	280	150	150	HANDWHEEL
3"	283	150	290	195	190	HANDWHEEL
4"	305	160	325	225	230	HANDWHEEL
6"	403	225	410	270	280	HANDWHEEL
8"	419	275	470	310	345	GEARBOX
10"	457	325	510	340	405	GEARBOX
12"	502	350	735	415	485	GEARBOX
14"	762	400	840	530	535	GEARBOX
16"	838	510	985	600	595	GEARBOX
20"	991	660	1130	690	700	GEARBOX
24"	1346	760	1260	800	815	GEARBOX
30"	1594	910	1385	970	*	GEARBOX

NOTE - Dimensions are for information only. Certified dimensional drawings are available upon request.

*NOTE - Larger sizes upon request.

Dual Expanding Plug Valve

COD.
APDB-3000

DEPV FULL BORE CLASS 300 2" TO 30"

PETROCHEMICAL
& ENERGY DIVISION

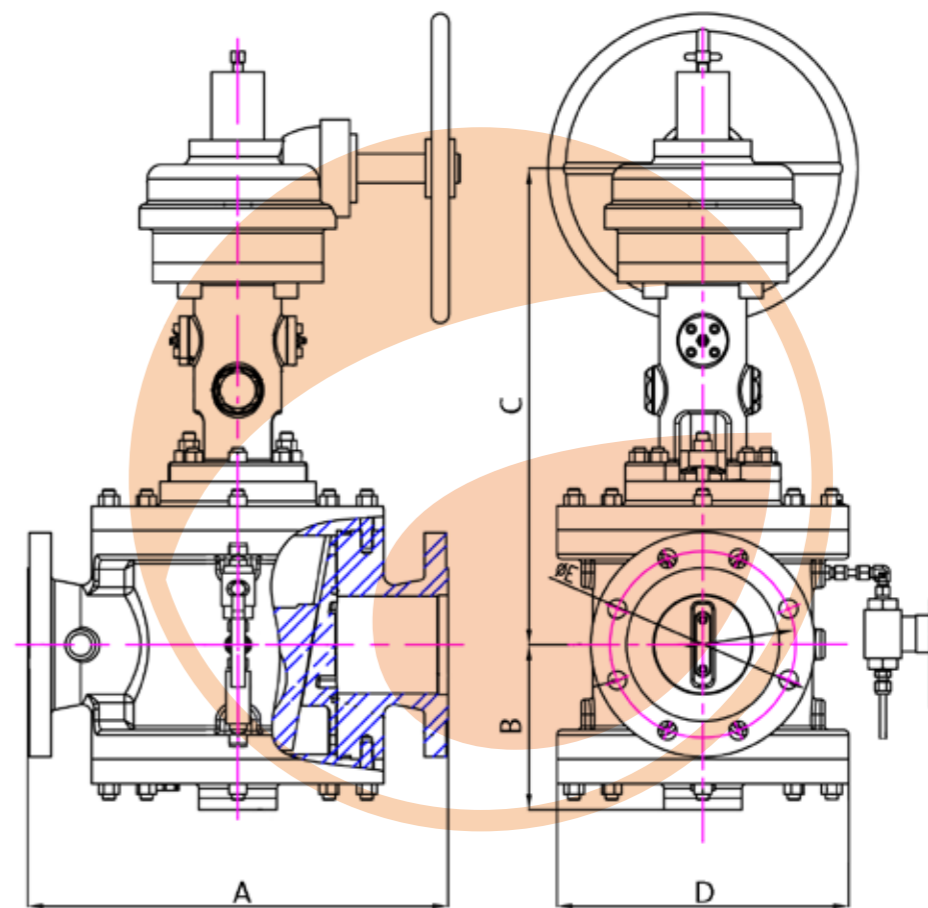

CLASS 300 FULL BORE

SIZE	A	B	C	D	E	OPERATOR
(inch)	(mm)	(mm)	(mm)	(mm)	(mm)	(mm)
2"	313	135	280	240	150	HANDWHEEL
3"	387	150	290	255	190	HANDWHEEL
4"	457	160	325	300	230	HANDWHEEL
6"	559	225	410	330	280	GEARBOX
8"	686	275	470	370	345	GEARBOX
10"	826	325	510	400	405	GEARBOX
12"	965	350	735	415	485	GEARBOX
14"	864	400	840	440	535	GEARBOX
16"	914	510	985	545	595	GEARBOX
20"	1245	660	1130	650	700	GEARBOX
24"	1394	760	1260	770	815	GEARBOX
30"	1727	910	1385	1040	*	GEARBOX

NOTE - Dimensions are for information only. Certified dimensional drawings are available upon request.

technical datas

Dual Expanding Plug Valve

COD.
APDB-6000

DEPV REDUCED BORE CLASS 600 2" TO 30"

PETROCHEMICAL
& ENERGY DIVISION

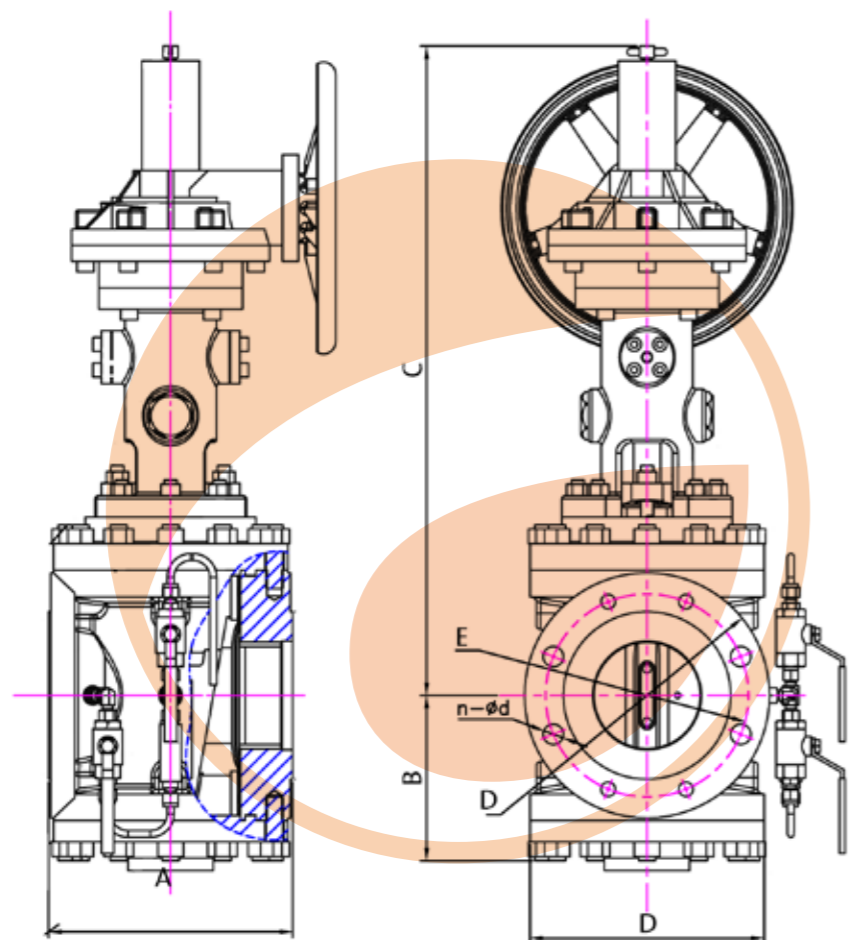

CLASS 600 REDUCED BORE

SIZE	A	B	C	D	E	OPERATOR
(inch)	(mm)	(mm)	(mm)	(mm)	(mm)	(mm)
2"	292	145	290	150	150	HANDWHEEL
3"	356	160	300	195	190	HANDWHEEL
4"	432	170	335	225	230	HANDWHEEL
6"	559	235	420	270	280	HANDWHEEL
8"	660	285	480	310	345	GEARBOX
10"	787	335	520	340	405	GEARBOX
12"	838	360	745	415	485	GEARBOX

NOTE - Dimensions are for information only. Certified dimensional drawings are available upon request.

*NOTE - Larger sizes upon request.

Dual Expanding Plug Valve

COD.
APDB-6000

DEPV FULL BORE CLASS 600 2" TO 12"

PETROCHEMICAL
& ENERGY DIVISION

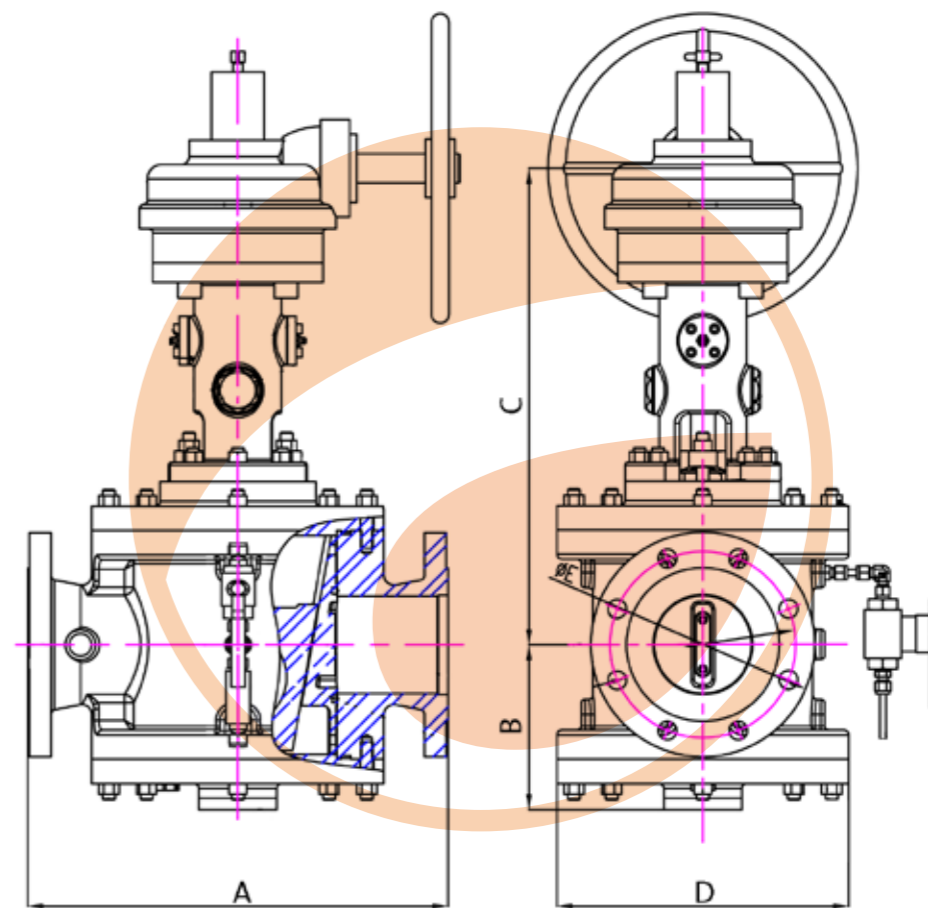

CLASS 600 FULL BORE

SIZE	A	B	C	D	E	OPERATOR
(inch)	(mm)	(mm)	(mm)	(mm)	(mm)	(mm)
2"	330	145	290	240	150	HANDWHEEL
3"	444	160	300	255	190	HANDWHEEL
4"	508	170	335	300	230	HANDWHEEL
6"	660	235	420	330	280	HANDWHEEL
8"	794	285	480	370	345	GEARBOX
10"	940	335	520	400	405	GEARBOX
12"	1067	360	745	415	485	GEARBOX

NOTE - Dimensions are for information only. Certified dimensional drawings are available upon request.

DESIGN STANDARDS:

The Dual Expanding Plug valves meet the international standards listed below:



- 1. API 6D:**
Pipeline Valves. Pressure Test Specification.
- 2. ANSI B 16.34:**
Valves-Flanged, Threaded, and Welding End.
- 3. ANSI B 16.5:**
Steel Pipe Flanges and Flanges Fittings, Flange dimensions.
- 4. ANSI B 16.10:**
Face-to-Face and End-to-End Dimensions of Ferrous Valves.
- 5. ANSI B 31.3:**
Chemical Plant and Petroleum Refinery Piping.
- 6. ANSI B 31.4:**
Liquid Petroleum Transportation Piping Systems.
- 7. API 598:**
Valve Inspection and Test. Optional Test Specification.
- 8. API 599:**
Steel Plug valves.
- 9. API RP6FA:**
Fire Test for Valves.

THE COMPETITIVE ADVANTAGES DUAL EXPANDING PLUG

- 1- DOUBLE BLOCK & BLEED**
Easier operation, lower costs of maintenance and space saving
- 2- BACK SEATING**
Stem packing easily replaced or adjusted, even if line is under pressure
- 3- LATEST DESIGN**
Our design is optimized by the most modern informatic technology, 3D design (Solid Works), finite element calculus, etc.
- 4- MANUFACTURING CAPACITY**
- 5- NO FRICTION**
Low operating torques and friction-free opening & closing.
- 6- MAINTENANCE AND SERVICEABILITY**
Easy access to the slips to change them quickly, if required. Low cost maintenance.
- 7- STEM PACKING**
with special requirements (i.e. TA-Luft, fugitive emissions, etc)
- 8- LOWER TRUNNION**
No body cavity therefore no accumulation of particles that could interfere with valve function.
- 9- DOUBLE GUIDED PLUG**
This assures the sealing of both slips equally



Absolute Regulation of Fluids





arflu
INDUSTRIAL VALVES

Absolute Regulation of Fluids



Factory
ARFLU, S.A.
Poligono Telleriondo, Calle Olabide 13
48600 SOPELANA (BIZKAIA) – SPAIN
Phone: ++ 34 - 94 676 60 01
Fax: ++ +34 - 94 676 41 22



PETROCHEMICAL
DIVISION

WATER
DIVISION

GAS
DIVISION

ENERGY
DIVISION

MARINE
DIVISION

www.arflu.com