



CE 0036



ChemValve-Schmid
Armaturentechnik



2008/11 :: | ::www.chemvalve-schmid.com:: | ::info@chemvalve-schmid.com:: | ::T:+41 32 639 50 10:: | ::F:+41 32 639 50 15::

::Data Sheet:: | ::Chapter 6::

Seite 1/3

::Check Valve Type CSC, CSCF:: | ::DN050 - 1000:: | ::PN10 - 40:: | ::ANSI150 - 300::

Check Valve Type CSC, CSCF DN050 - 1000

Designation	Material
Body	see table
Disc	see table
Soft sealing	see table
Spring DN050-200 (CSCF)*	see Pricelist
Centre ring	see Pricelist

*optional

Technical specifications

Placement between flange according to DIN EN 1092-1, PN10

Max. nominal pressure PN40

Operational limits according to DIN EN 1092-1

Tightness according to DIN EN 12266-1, Leakage Rate D (Sealing M, T) and Leakage Rate A (Sealing E, P, V)

Identification according to DIN EN 19

Short weight-saving overall lengths

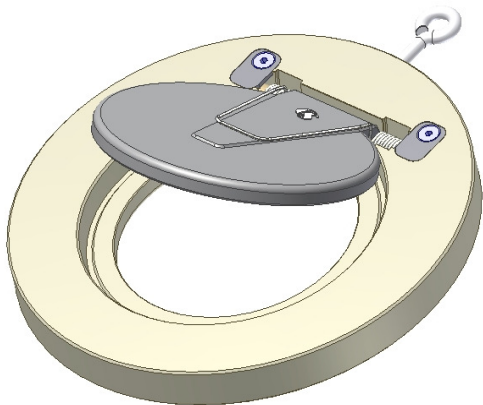
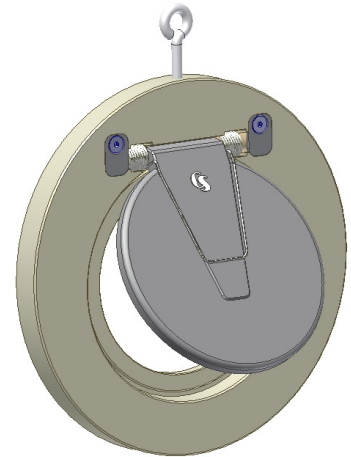

Utilisation

For liquids, gases and steams in all process technology

Constructional features

Cast Disc with opening limit (Standard)

Optional spring (→CSCF) Same overall length for CSC (without spring) and CSCF (DN050 – 200 with spring)

Ring Screw for mounting (Standard)

Centering by the outside diameter of the body or centre ring

Flange connection with grooves (Standard)

Special types

Placement between flange according to DIN EN 1092-1, PN16-40 and ANSI B16.5 CL.150-300 lbs with centre ring according to the following page

Flange connection with soft sealings replaces flange gaskets (see drawings)

Designation: CSC- 64 64 - E - 100
CSC- □□ - □□ - □ - □□□ → DN050 - 450

Body

Disc

Soft sealing

Material	Nr.	Code	Material	Nr.	Code	Material	Temperatur	
Stainless steel	1.4301	11	Stainless steel	1.4581	11	metallic		C
Steel	1.0619	27	Steel	1.0619	27	EPDM	-50 bis 130°C	O
Bronze	2.1090	33	Bronze	2.1050	33	NBR	-30 bis 120°C	d
Austenit	1.4404	64	Austenit	1.4404	64	VITON	-20 bis 200°C	e
Polypropylen	PP	74	Polypropylen	PP	74	PTFE	-200 bis 200°C	M
PTFE+25%Glas	PTFE	75	PTFE+25%Glas	PTFE	75			E

Subject to change without notice



CE 0036



ChemValve-Schmid
Armaturentechnik



2008/11 :: | ::www.chemvalve-schmid.com:: | ::info@chemvalve-schmid.com:: | ::T:+41 32 639 50 10:: | ::F:+41 32 639 50 15::

::Data Sheet:: | ::Chapter 6::

Seite 2/3

::Check Valve Type CSC, CSCF:: | ::DN050 - 1000:: | ::PN10 - 40:: | ::ANSI150 - 300::

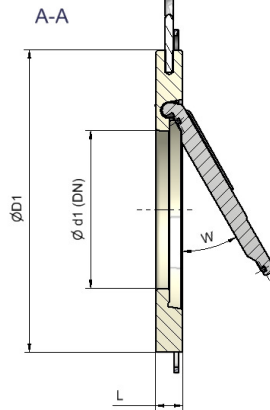
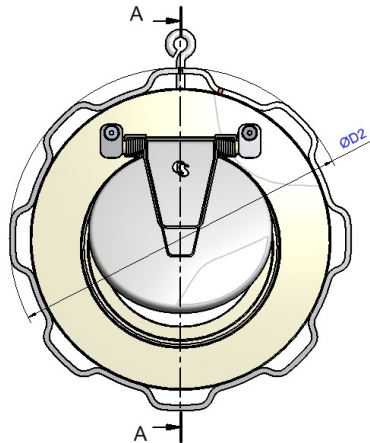

DN (mm)	050	065	080	100	125	150	200
DN (zoll)	2"	2 1/2"	3"	4"	5"	6"	8"
L	16.5	16.5	17.5	17.5	19.5	19.5	30.0
Ø D1, PN10	107	127	142	162	192	218	273
Ø D1, PN16	107	127	142	162	192	218	273
Ø D1, D2, PN25	107	127	142	170	192	226	283
Ø D1, D2, PN40	107	127	142	170	192	226	290
Ø D1, D2, ANSI150	101	120	133	170	192	218	273
Ø D1, D2, ANSI300	107	127	142	177	212	247	304
Weight (kg)	1.2	1.6	2.1	2.6	4	6	12

The pressure rates marked in blue are indicating the use of a centre ring. (See extra charges on the price list).
D2 shows the outer diameter of the centre ring.

Opening pressures (mbar)

DN (mm)	050	065	080	100	125	150	200
DN (zoll)	2"	2 1/2"	3"	4"	5"	6"	8"
CSC, ΔP ↑	15	13	13	11	10	13	19
CSC, ΔP →	0	0	0	0	0	0	0
CSCF, ΔP ↑ with spring	23	21	21	19	18	21	27
CSCF, ΔP → with spring	8	8	8	8	8	8	8
Kv-Wert m3/h	54	75	112	172	342	490	1128

Pressure drop diagramm

Pressure drop diagram for water at 20°C with opened valve and horizontal flow.
For calculating the pressure drop of the medium the equivalent water flow volume has to be calculated.

$$\dot{V}_w = \dot{v} \sqrt{\frac{\rho}{1000}}$$

- \dot{V}_w = Equivalent water flow in m3/h
- ρ = Density of the medium (in use) in kg/m3
- \dot{v} = Flow volume of the medium (in use) in m3/h

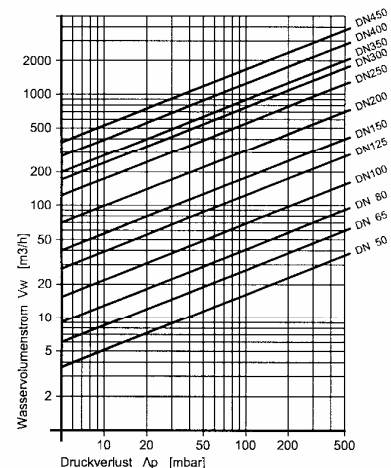



CE 0036



ChemValve-Schmid
Armaturentechnik



2008/11 :: | ::www.chemvalve-schmid.com:: | ::info@chemvalve-schmid.com:: | ::T:+41 32 639 50 10:: | ::F:+41 32 639 50 15::

::Data Sheet:: | ::Chapter 6::

Seite 3/3

::Check Valve Type CSC, CSCF:: | ::DN050 - 1000:: | ::PN10 - 40:: | ::ANSI150 - 300::

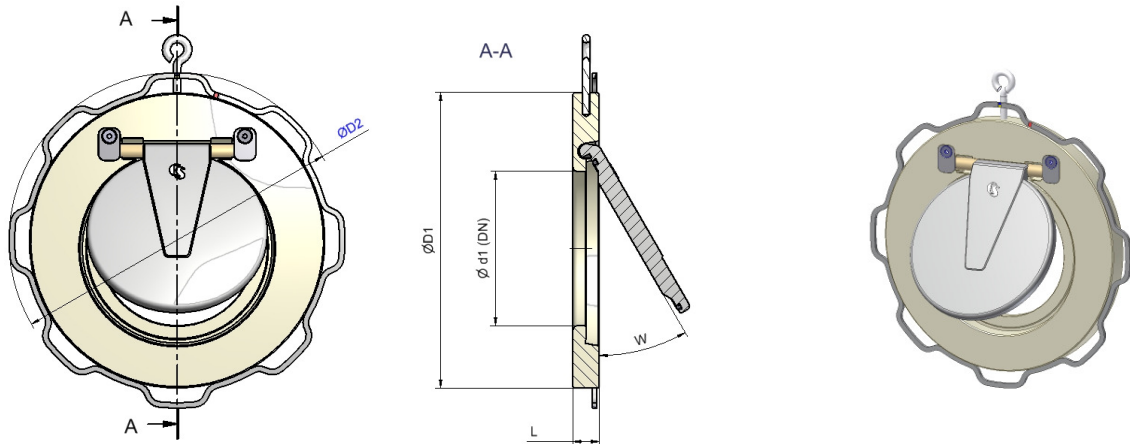

DN (mm)	250	300	350	400	450	500	600	700	800	900	1000
DN (Zoll)	10"	12"	14"	16"	18"	20"	24"	28"	32"	36"	40"
L	30.0	34.0	34.0	39.0	39.0	65	70	76	89	95	127
Ø D1,PN10	328	378	438	489	539	594	695	810	920	1020	1127
Ø D1,PN16	328	378	444	495	555	617	734	804	914	1014	1131
Ø D1,D2,PN25	338	400	457	514	564	624	731	833	945	1045	1158
Ø D1,D2,PN40	352	417	474	546	571	628	747				
Ø D1,D2,ANSI150	338	400	447	511	546	603	714				
Ø D1,D2,ANSI300	352	417	482	536	593	650	771				
Weight (kg)	17	28	41	61	73	108	159	229	350	460	742

The pressure rates marked in blue are indicating the use of a centre ring. (See extra charges on the price list).
D2 shows the outer diameter of the centre ring.

Opening pressures (mbar)

DN (mm)	250	300	350	400	450	500	600	700	800	900	1000
DN (Zoll)	10"	12"	14"	16"	18"	20"	24"	28"	32"	36"	40"
CSC, ΔP ↑	18	21	22	26	28	34	32	35	44	50	60
CSC, ΔP →	0	0	0	0	0	0	0	0	0	0	0
Kv-Wert m3/h	1500	2290	2890	3700	5000						

Pressure drop diagramm

Pressure drop diagramm for water at 20°C with opened valve and horizontal flow.
For calculating the pressure drop of the medium the equivalent water flow volume has to be calculated.

$$\dot{V}_w = \dot{v} \sqrt{\frac{\rho}{1000}}$$

- \dot{V}_w = Equivalent water flow in m3/h
- ρ = Density of the medium (in use) in kg/m3
- \dot{v} = Flow volume of the medium (in use) in m3/h

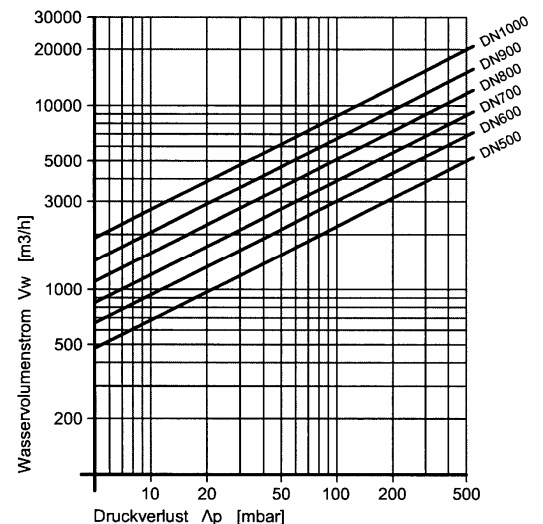

Subject to change without notice